

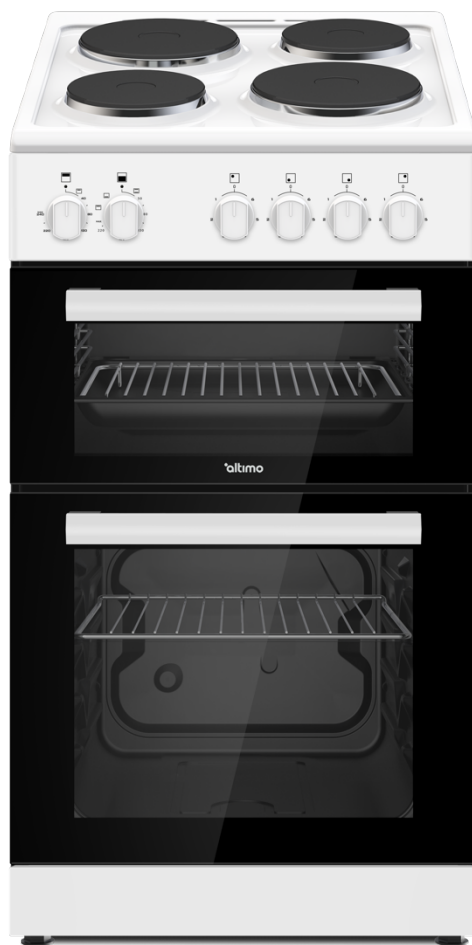

# Instruction Manual



**50cm Twin Cavity Freestanding Cooker**

**CETS502W / CETS502B**

# Contents

## 1 Safety information

Safety information	3
--------------------	---

## 2 Getting to know your Freestanding Cooker

Overview	5
Accessories	6

## 3 Installing your Freestanding Cooker

Installation requirements	7
Electrical connection	9

## 4 Using your Freestanding Cooker

Control panel	10
Oven functions	11
General oven and cooking tips	12
Practical Cooking Advice	13
Using the solid plate zones of your cooker	14

## 5 Care and Maintenance

Cleaning	15
Replacing oven lamps	16
Technical specification	17

## 6 Product support

Troubleshooting	20
Help and assistance	21
Your appliance guarantee	22
Declaration of conformance to product standards	23
Disposal	23

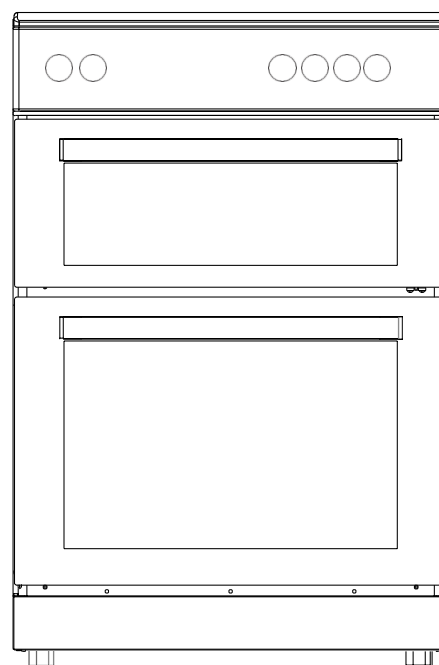



## Safety information

**Important** - Please read these instructions fully before installing or operating

### INSTALLATION WARNINGS

**IMPORTANT:** Prior to installation ensure that the local supply conditions (electricity, voltage and frequency) are compatible with the requirements of your freestanding cooker.

**IMPORTANT:** Carefully unpack and examine the appliance for any damage. If you think there is a defect, do not use the appliance and contact Product Support on 0330 041 7490. Packaging materials should be collected together and disposed of immediately as they may be harmful to children.

**IMPORTANT:** Keep the electrical cable (not supplied) of your freestanding cooker away from the hot areas of your appliance, do not let the cable touch the appliance. Keep the cable away from sharp edges and heated surfaces.

**IMPORTANT:** Ensure that the electric supply cable is not trapped or damaged during installation.

**IMPORTANT:** In the event that the cable connecting your freestanding cooker becomes damaged, it must be replaced by a suitably qualified person. This cable must not be replaced by an unauthorised person.

**IMPORTANT:** Protect your freestanding cooker against atmospheric effects. Do not expose your cooker to effects such as sun, rain, snow etc.

**IMPORTANT:** The materials surrounding the appliance (cabinets) must be able to withstand a minimum temperature of 100°C.

**IMPORTANT:** When using your oven for the first time your cooker may give off an unusual odour from the heating elements and insulation materials. To eliminate this odour, run the oven at 250°C for 40-60 minutes with the oven empty.

**WARNING:** Before obtaining access to terminals, all supply circuits must be disconnected.

### DURING USAGE

**IMPORTANT:** This appliance can be used by children aged from 8 years and above and persons with reduced physical, sensory or mental capabilities or lack of experience and knowledge if they have been given supervision or instruction concerning use of the appliance in a safe way and understand the hazards involved. Children should not play with the appliance. Cleaning and user maintenance should not be made by children without supervision.

**WARNING:** The appliance and its accessible parts become hot during use. Care should be taken to avoid touching heating elements.

**WARNING: NEVER** try to extinguish a cooking fire with water. Instead, switch off the appliance and cover the flame e.g. with a lid or a fire blanket.

**CAUTION:** Do not allow children in the kitchen when cooking or after, as the appliance may still be hot. Many parts of the cooker will become hot and present a considerable hazard to children.

**CAUTION:** When the cooker is hot, never touch the oven glass by hand or with tools.

**CAUTION:** Before starting to use your appliance, ensure curtains, paper or flammable items are kept away from your appliance. Do not keep flammable materials inside or around your cooker.

**CAUTION:** Take care when closing the oven door that there is nothing obstructing it from closing as this may break the glass.

**IMPORTANT:** When using the grill, the oven door must be kept closed.



## Safety information

**Important** - Please read these instructions fully before installing or operating

**IMPORTANT:** Make sure the cooker control knobs are all in the off position when not in use.

**IMPORTANT:** If you do not intend to use your cooker for a long period of time, turn off the electric supply to the cooker.

### GENERAL SAFETY WARNINGS

**IMPORTANT:** This appliance has been designed for non-professional, domestic use only. Do not use this oven for commercial use or any other application e.g. room heating.

**WARNING:** Danger of fire - do not store flammable items on or near the cooking surfaces or inside the oven.

**IMPORTANT:** Do not try to lift or move this appliance by pulling on the door handle.

**WARNING:** Ensure that the appliance is switched off before replacing the lamp to avoid the possibility of electric shock.

**IMPORTANT:** Your appliance is produced in accordance with all applicable local and international standards and regulations.

**IMPORTANT:** Maintenance and repair work must only be performed by authorised service technicians. Installation and repair work that is carried out by unauthorised technicians is dangerous and could invalidate your guarantee.

**IMPORTANT:** When the door of the oven is open, do not hang or lean anything on it. You may unbalance your appliance or damage the door or door hinges.

**IMPORTANT:** Do not hang towels, dishcloths or clothes from the cooker or its handles.

### CLEANING AND MAINTENANCE

**IMPORTANT:** Always turn the appliance off before operations such as cleaning or maintenance. You can do this by switching the freestanding cooker off using the cooker isolation switch.

**IMPORTANT:** Do not remove the control knobs to clean the control panel.

**WARNING:** Do not use harsh abrasive cleaners or sharp metal scrapers to clean the oven door glass since they can scratch the surface, which may result in shattering of the glass.

**TO MAINTAIN THE EFFICIENCY AND SAFETY OF YOUR APPLIANCE, WE RECOMMEND YOU ALWAYS USE OUR AUTHORISED SERVICE AGENTS AND ORIGINAL SPARE PARTS.**

**IF YOU REQUIRE ASSISTANCE WITH THE OPERATION OF YOUR APPLIANCE, PLEASE CALL OUR PRODUCT SUPPORT TEAM ON 0330 041 7490.**

**TROUBLESHOOTING ADVICE CAN BE FOUND ON PAGE 20. IF YOUR APPLIANCE IS FAULTY AND NEEDS A REPAIR, PLEASE CALL 01759 487835.**

# Getting to know your Freestanding Cooker

## Overview

1. Solid plate
2. Thermostat knob
3. Function knob for oven
4. Hob temperature knobs
5. Upper cavity door
6. Upper cavity handle
7. Adjustable feet
8. Grill pan
9. Lamp
10. Wire shelf

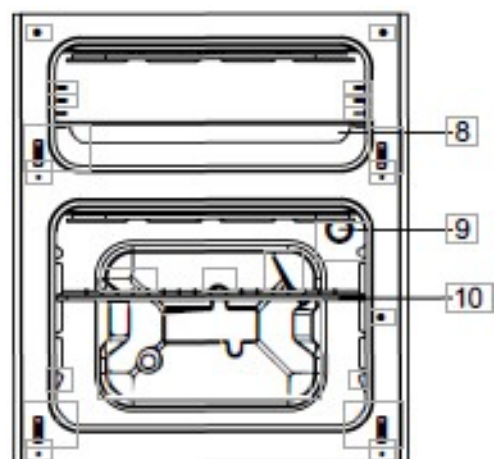
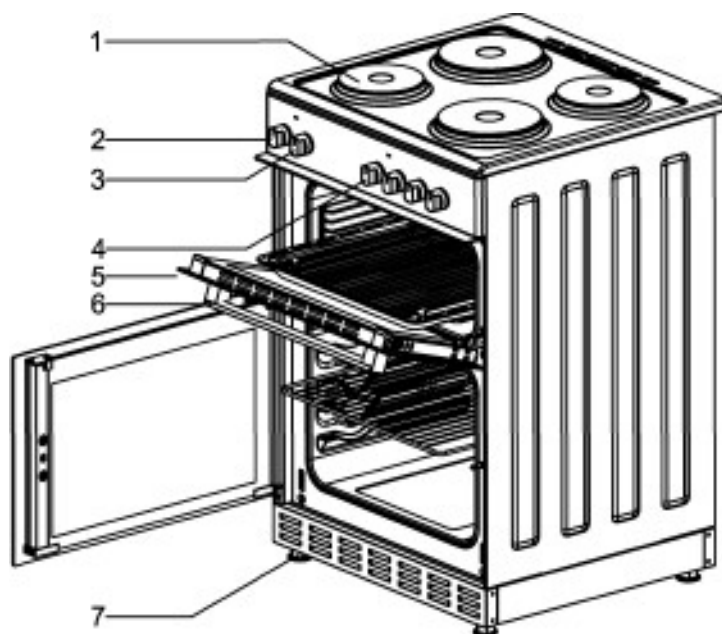

# Getting to know your Freestanding Cooker

## Accessories

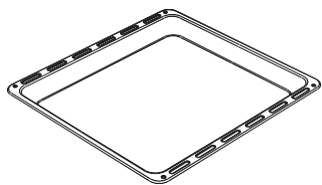

### **Metal tray**

Used for pastry (cookie, biscuits etc.), frozen foods.

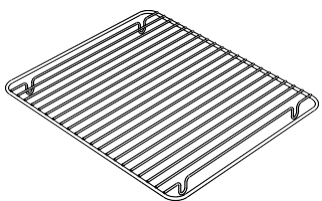

### **In tray wire grill**

Used with the grill for toasting bread or grilling other foods.

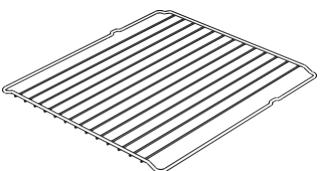

### **Wire grill**

Used for cooking foods that are not suitable in baking trays - ie Pizzas.

# Installing your Freestanding Cooker

## Installation requirements

THIS COOKER MUST BE INSTALLED BY A QUALIFIED INSTALLER IN ACCORDANCE WITH LOCAL REGULATIONS



**IMPORTANT: CONTACT AN AUTHORISED SERVICE AGENT FOR INSTALLATION OF YOUR FREESTANDING COOKER!**

## Positioning

1. Make sure that there are no combustible or flammable materials, such as curtains, in the vicinity of the installation.
2. Furniture and cabinets surrounding the cooker must be of material resistant to temperatures greater than 100°C.
3. Surrounding furniture, cabinets and extractor fans should be positioned in accordance with the diagram shown in the figure.
4. There must be at least 2cm of free space between the back wall and the rear of the appliance to allow for ventilation and air circulation.
5. If fitted, the extractor fan must be at least 700mm above the hotplates. If no fan is fitted, the minimum distance between the hotplates and any cabinet or other structure must be 700mm.

## First Use

**IMPORTANT:** When using your oven for the first time your cooker may give off an unusual odour from the heating elements and insulation materials. This is normal for new cookers. To eliminate this odour, run the oven at 250°C for 40-60 mins with the oven empty.

## Unpacking

Carefully unpack and examine the appliance for any damage. If you think there is a defect, do not use the appliance and contact Product Support on 0330 041 7490.

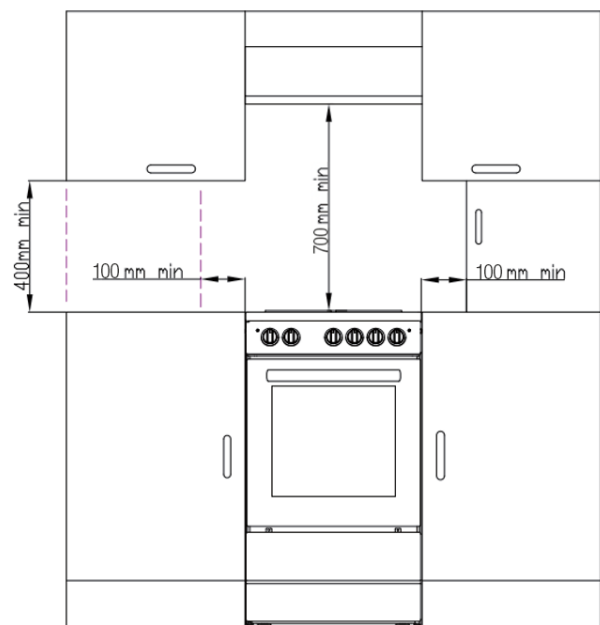

# Installing your Freestanding Cooker

## Levelling feet

The height and level of the appliance can be adjusted by rotating the feet located underneath the appliance at each corner. Rotate the feet to decrease or increase the height.

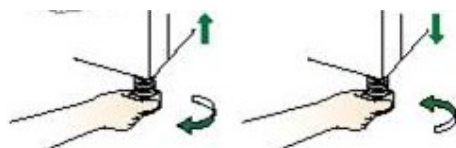

## Safety chain

The appliance must be secured against the possibility of tipping forward by using the supplied safety chains attached to the rear of your oven.

Fasten the stability hook provided by inserting a wall plug into the kitchen wall and then connect the safety chain to the hook via the locking mechanism.

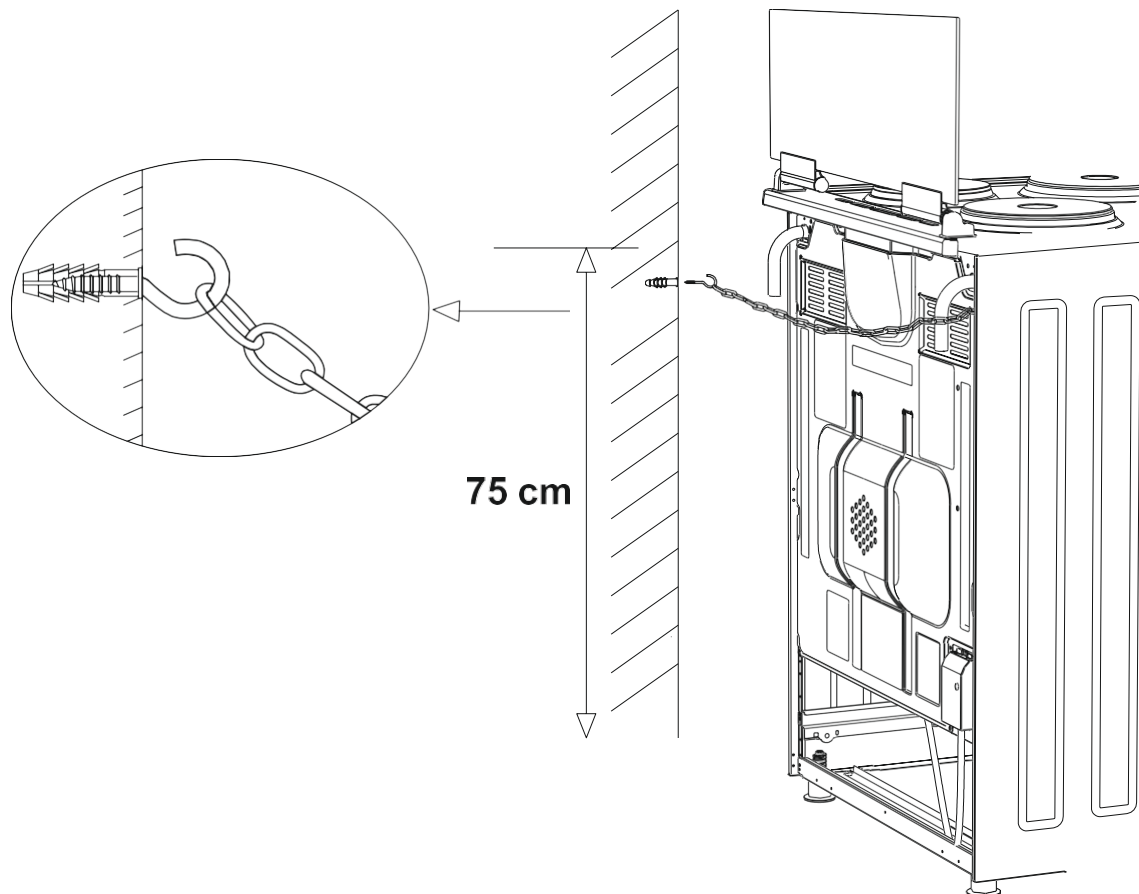



# Installing your Freestanding Cooker

## Electrical connection

**IMPORTANT:** Electrical connections must be carried out by a suitably qualified person and in accordance with all relevant local building and installation regulations.

### Fitting a Power Supply Cable

Connecting appropriate power supply terminal board/connector block:

- Using a screwdriver, prize open tabs of the Terminal board cover.
- Remove the wire clamp screw.
- Fasten the wires beneath the corresponding screw heads.
- Fasten cable clamp and close the cover of the terminal board.
- The ac power supply should be 220-240V, 50/60 Hz. For electric cookers, the minimum 32A fuse, or at least a 32A distribution circuit breaker.

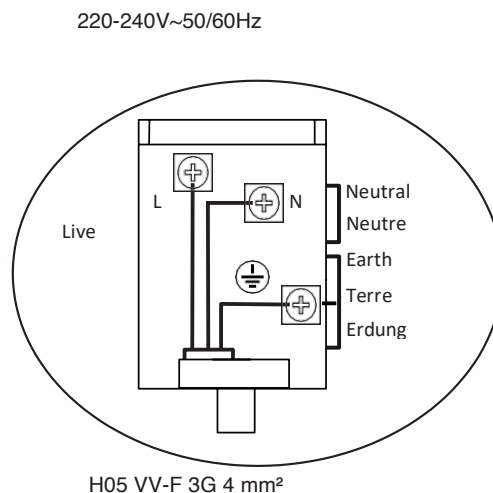

### Connecting the supply cable to the mains

Install an approved circuit breaker with a minimum contact opening of 3mm, between the appliance and the mains fuse box. The circuit breaker should be sized according to the load and should comply with current regulations (the earth wire should not be interrupted by the circuit breaker).

The supply cable should be positioned so that it does not reach a temperature of more than 50°C with respect to the room temperature, anywhere along its length. Before switching the fuse ON in the meter-box check:

- Earth continuity - the electrical safety of this appliance can only be guaranteed if the cooker is correctly installed and earthed, in compliance with regulations on electrical installations.
- That the electrical capacity of the system and sockets will support the maximum power of the appliance, as indicated on the data plate.

# Using your Freestanding Cooker

## Control panel

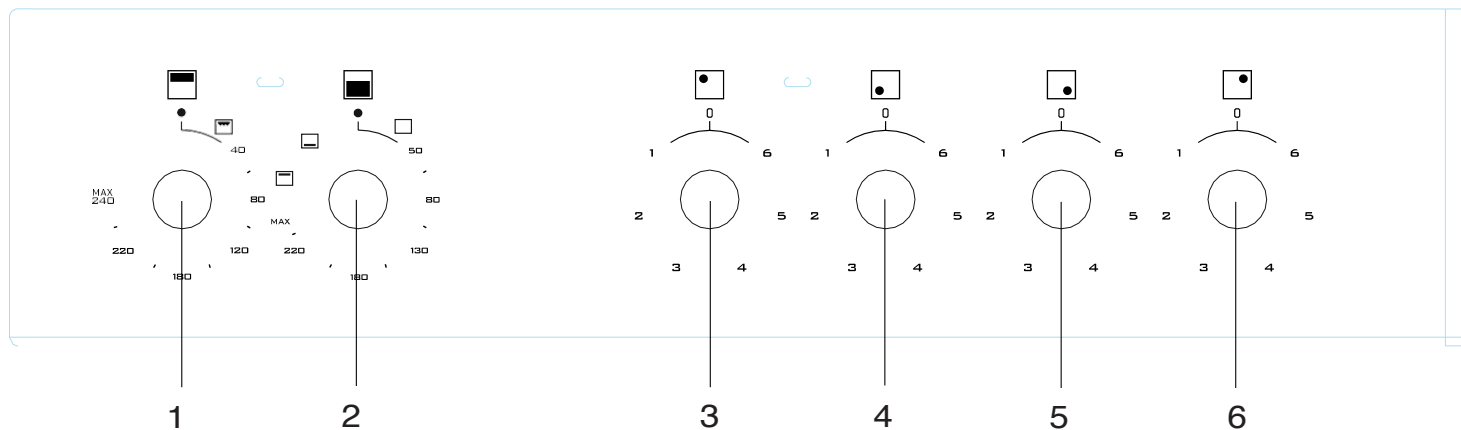

- 1. Thermostat**
  - Sets temperature for the grill.
- 2. Function**
  - Sets function & temperature for cooking in main oven.
- 3. Back Left Hob**
  - Adjusts temperature of hotplate.
- 4. Front Left Hob**
  - Adjusts temperature of hotplate.
- 5. Front Right Hob**
  - Adjusts temperature of hotplate.
- 6. Back Right Hob**
  - Adjusts temperature of hotplate.

# Using your Freestanding Cooker

## Oven functions



Grill



Top & Bottom Element



Bottom Element



Oven light

**Grill** - The top central heating elements come on. The extremely high and direct temperature of the grill makes it possible to brown the surface of meats and roasts while locking the juices in to keep them tender. The grill is also highly recommended for dishes that require a high temperature on the surface: beef steaks, veal, rib steak, fillets, hamburgers etc.

**Top & Bottom Element** - Hot air comes from the upper and lower elements in the oven. This is called Conventional cooking and is ideal for joints of meat.

**Bottom Element** - Bottom element cooking is used for foods that typically need cooking with heat from underneath. Cakes and bread are examples of where this function would be useful.

**Oven light** - The oven light will operate on all oven functions.

## Using your appliance for the first time

The first time you use your appliance, we recommend that you set the temperature setting to the highest mark. Set the function switch control knob to a cooking mode and leave the oven on for about 40-60 minutes with nothing in it and the oven door shut. Then, open the oven door and allow the oven to cool. Any odour that may be detected during this initial use is due to the evaporation of substances used to protect the oven during storage.

# Using your Freestanding Cooker

## General oven and cooking tips

### General Oven Tips:

The wire shelves should always be pushed firmly to the back of the oven.

Baking trays with food cooking on them should be placed level with the front edge of the oven's wire shelves. Other containers should be placed centrally. Keep all trays and containers away from the back of the oven, as over-browning of the food may occur.

For even browning, the maximum recommended size of a baking tray is 340 mm (13½") by 340 mm (13½").

When the oven is on, do not leave the door open for longer than necessary, otherwise the knobs may get very hot.

- Always leave 1cm gap between dishes on the same shelf. This allows the heat to circulate freely around them.
- To reduce fat splashing when you add vegetables to hot fat around a roast, dry them thoroughly or brush lightly with cooking oil.
- Where dishes may boil and spill over during cooking, place them on a baking tray.

# Using your Freestanding Cooker

## Practical Cooking Advice

The oven offers a wide range of alternatives that allow you to cook any type of food in the best possible way. With time, you will learn how to make the best use of this versatile cooking appliance. The following directions are only a guideline, which may be varied according to your own personal experience.

### Preheating

You should always preheat your oven before placing food in it to cook.

Once the food has been placed in the oven, the most appropriate cooking mode can then be selected.

### Using the Grill

Use the grill mode  placing the food under the centre of the grill (situated on the 3rd or 4th rack from the bottom) due to the central part of the top heating element being active.

Please use the grill pan set provided ensuring that there are no unwanted spillages formed inside your oven. When using this mode, we recommend that you set the thermostat to the highest setting. However, this does not mean that you cannot use lower temperatures, by simply by adjusting the thermostat knob to the desired temperature.

When using this mode, we advise you to set the thermostat to 200°C, as it is the most efficient way to use the grill.

### Baking Cakes

When baking cakes, always place them in a preheated oven. Make sure you wait until the oven has been preheated thoroughly. To prevent cakes from dropping or sinking, do not open the oven door during baking.

#### If the cake or pastry is too dry

Increase the temperature by 10°C and reduce the cooking time.

#### If the cake or pastry dropped

Use less liquid or lower the temperature by 10°C.

#### If the cake or pastry is too dark on top

Place it on a lower rack, lower the temperature, and increase the cooking time.

#### If the cake or pastry is cooked well on the inside but sticky on the outside

Use less liquid, lower the temperature, and increase the cooking time.

#### If the cake or pastry sticks to the pan

Grease the pan well and sprinkle it with a dusting of flour or use greaseproof paper.

Use a lower temperature setting. It is not necessary to remove the food from all the racks at the same time.

### Cooking Fish and Meat

When cooking white meat, fowl and fish, use temperature settings from 180°C to 200°C.

For red meat that should be well done on the outside while tender and juicy in the inside, it is a good idea to start with a high temperature setting (200°C-220°C) for a short time, then turn the oven down afterwards.

In general, the larger the roast, the lower the temperature setting. Place the meat on the centre of the grid and place the dripping pan beneath it to catch the fat.

Make sure that the grid is inserted so that it is in the centre of the oven. If you would like to increase the amount of heat from below, use the low rack heights. For savoury roasts (especially duck and wild game), dress the meat with lard or bacon on the top.

# Using your Freestanding Cooker

## Using the hotplates of your cooker

- Do not use pots and pans which are unsteady, as these could become un-sturdy.
- Do not use mats, heat diffusers or wok stands. These will cause a temperature build-up which can damage the hob.
- Do not let cooking pots overflow; this could leave a mark and residue on the hob.

### Choosing Cooking Pots

Look at this diagram below which shows you which pans to use on the hotplates and which pans should not be used.

- Always use pots and pans with flat bottoms. Uneven or thin bottoms will waste energy and cook slowly.
- Always use pots and pans which are slightly larger than the hotplate. Small pans waste energy.
- Always put dry pots and pans on the hotplates.

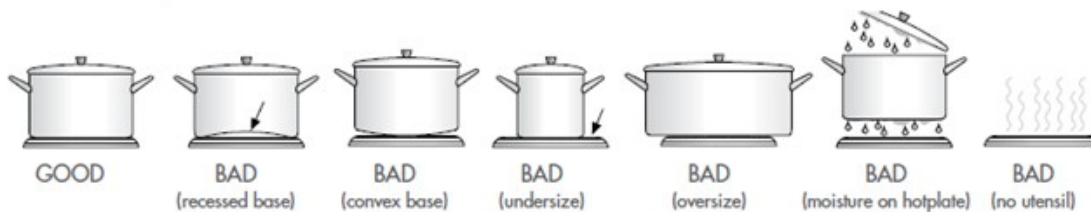

### Solid Hotplates

- The strong solid-cast hotplates give wide contact for cooking.
- The hotplates are sealed all around which means that spilt liquids cannot get under the hotplates.

### Before first use

- The top surface of the hotplates are sealed with a heat resistant coating. Before using for the first time, the hotplates should be heated for a short period without a pan to harden the protective coating.
- Turn the heat setting to high for approx. 3 minutes to fully harden the coating. When the hotplates have cooled, apply a thin coating of cooking oil to the hotplate to seal and protect the surface.

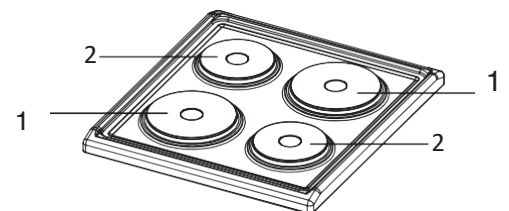

# Care and maintenance

## Cleaning

**WARNING!** Isolate the power supply to the appliance and make sure that the cooker is cool.

Before cleaning your cooker or performing maintenance, make sure that the cooking mode selection knob and the cooking temperature selection knob is set to 'OFF'. To extend the life of your cooker, it must be cleaned frequently. The inside of the cooker should preferably be cleaned immediately after use, when it is still warm (but not hot), with warm water and soap. The soap should be rinsed away and the interior dried thoroughly. Avoid using abrasive detergents, scourers, acidic cleaners such as lime scale remover, etc, as these could damage the enamel, and can result in the development of rust and corrosion. If stains are particularly tough to remove, use cleaners specifically recommended to clean cookers and follow the instructions provided with the cleaner.

Never use a steam cleaner for cleaning inside the cooker.

Do not clean using caustic creams, abrasive cleaning powders, thick wire wool or hard tools. Enamelled parts of the cooker can be damaged if excess cleaning liquids are not immediately removed.

After cleaning the interior parts of the cooker with a soapy cloth, rinse it and then dry thoroughly with a soft cloth.

Clean the glass surfaces with special glass cleaning agents.

Never use flammable agents like acid, thinner or petrol when cleaning your appliance.

Do not clean your cooker with a steam cleaner.

Do not wash any part of your cooker in a dishwasher.

### **Enamelled Parts:**

In order to keep enamelled parts as new, it is necessary to clean them frequently with mild warm soapy water and then dry with a cloth. Do not wash them while hot and never use abrasive powders or abrasive cleaning materials. Do not leave anything spilled onto enamelled parts for long periods of time.

### **Stainless Steel:**

Stainless steel parts must be cleaned frequently with mildly warm soapy water and a soft sponge and then dried with a soft cloth. Do not use abrasive powders or abrasive cleaning materials. Do not leave anything spilled onto stainless steel parts for long periods of time.

# Care and maintenance

## Replacing the oven lamps

- Disconnect the oven from the power supply at the fuse-box by means of the switch used to connect the appliance to the electrical mains or unplug the appliance.
- Remove the glass cover of the lamp-holder by rotating anti-clockwise.
- Remove the lamp and replace with a lamp resistant to high temperatures (300°C) with the following characteristics:

Voltage: 220-240V

Wattage: 25W

Type: G9

- Replace the glass cover. Reconnect the appliance to the mains power supply.

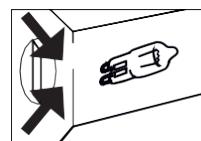
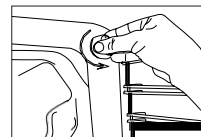

## Cleaning the oven door / How to remove the oven doors

For a more thorough clean, you can remove and disassemble the oven door. Proceed as follows using the oven door removal and assemble procedure:

- Open the door to the full extent (fig.1).
- Open lever A completely on the left and right hinges (fig.2).
- Hold the door as shown in (fig.3).
- Gently close the door (fig.3) until the left and right hinge levers (A) are hooked to part B of the door (fig.4).
- Withdraw the hinge hooks from their location following arrow C (fig.4).
- Rest the door on a soft surface.
- To replace the door, repeat the above steps in reverse.

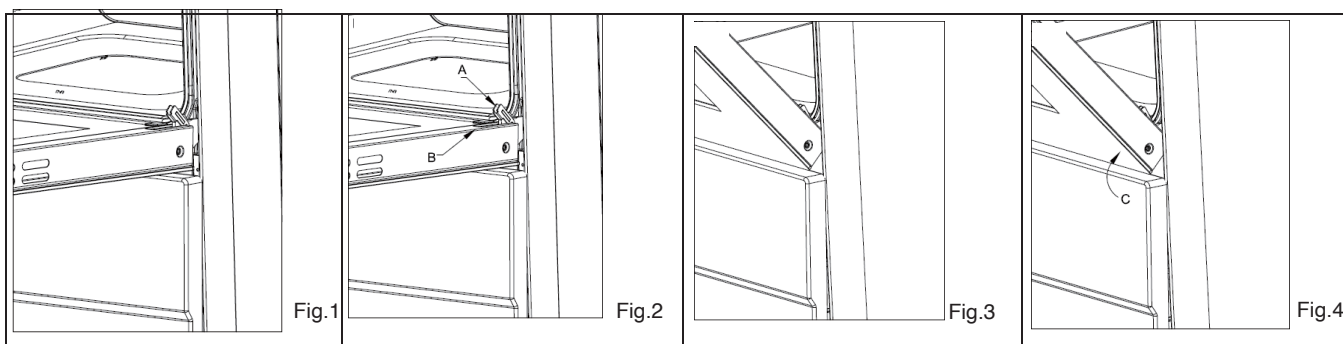



# Care and maintenance

## Technical specification

Model	CETS502W / CETS502B
Voltage and frequency	220-240V AC/50Hz
Top oven power	1400W
Bottom oven power	1815W
Top oven usable capacity	23L
Oven usable capacity	48L
Power consumption for big hot plate	1500W (x2)
Power consumption for small hot plate	1000W (x2)
Total hot plate power consumption	5000W
Total power	8215W

We apologise for any inconvenience caused by minor inconsistencies within these instructions that may occur due to product improvements and development. All images and drawings are for illustration purposes only.

**PRODUCT FICHE**

Comply with Energy Label Directive Eu 2010/30/EU - Regulation No 65/2014 of ovens according to EN 60350-1 or EN 15181

Comply with EU directive 2009/125/EC- regulation No 66/2014 according to EN 60350-1 or EN 15181

Brand	<b>ALTIMO</b>		
Model	<b>CETS502W / CETS502B</b>		
Type of oven	Free Standing	X	
	Built-in		
Mass of the appliance(M)(Net weight)kg	<b>44,2</b>	kg	
Number of cavities	2		
Heat source per cavity	Electrical	X	
	Gas		
	Mix		
Volume per cavity	<b>48</b>		
Energy consumption (electricity) required to heat a standardised load in a cavity of an electric heated oven during a cycle in conventional mode per cavity (electric final energy)	EC electric cavity	<b>0.71</b>	kWh/cycle
Energy consumption required to heat a standardised load in a cavity of an electric heated oven during a cycle in fan-forced mode per cavity (electric final energy)	EC electric cavity		kWh/cycle
Energy consumption required to heat a standardised load in a gas-fired cavity of an oven during a cycle in conventional mode per cavity (gas final energy)	EC gas cavity		MJ/cycle kWh/cycle (1)
Energy consumption required to heat a standardised load in a gas-fired cavity of an oven during a cycle in fan-forced mode per cavity (gas final energy)	EC gas cavity		MJ/cycle kWh/cycle (1)
Energy Efficiency Index per cavity	EEL cavity	<b>94,7</b>	
Energy Efficiency Class	<b>A</b>		
(1) 1 kWh/cycle= 3,6 MJ/cycle.			

<b>PRODUCT FICHE</b>		
Information for domestic electric hobs		
Comply with EU directive 2009/125/EC - Regulation No 66/2014 according to EN 60350-2		
Brand	<b>ALTIMO</b>	
Model	<b>CETS502W / CETS502B</b>	
Type of hob	Electrical	<b>X</b>
	Gas	
	Mix	
Number of cooking zone and or area		<b>4</b>
Heating Technology	Radiant Cooking zone	
	Induction Cooking zone	
	Solid Plates Cooking zone	<b>X</b>
For circular cooking zones or area: diameter of useful surface area per electric heated cooking zone, rounded to the nearest 5 mm(0/cm)	Front Left Zone	<b>14,5</b>
	Rear left zone	<b>18</b>
	Front right zone	<b>18</b>
	Rear right zone	<b>14,5</b>
	Front centre zone	
	Rear centre zone	
For non-circular cooking zones or areas: length and width of useful surface area per electric heated cooking zone or area, rounded to the nearest 5mm (LxW) cm	Front left zone	
	Rear left zone	
	Front right zone	
	Rear right zone	
	Front centre zone	
	Rear centre zone	
Energy consumption per electric cooking zone or area calculated per kg EC electric cooking Wh/kg	Front left zone	<b>193</b>
	Rear left zone	<b>193</b>
	Front right zone	<b>193</b>
	Rear right zone	<b>193</b>
	Front centre zone	
	Rear centre zone	
Energy consumption for the hob calculated per kg EC electric hob (Wh/kg)		<b>193</b>

# Product support

## Troubleshooting

If you have a problem with your appliance, check the troubleshooting table below to try and rectify your problem before calling your product support service centre.

Problem	Causes	What to do
Oven or grill not working	Power not turned on	Switch on electricity
	Household fuse blown	Check fuses
	Controls incorrectly set	Reset controls
	Circuit breaker tripped	Check circuit breaker
Oven light not working	Power not turned on	Switch on electricity
	Household fuse blown	Check fuses
	Circuit breaker tripped	Check circuit breaker
	Lamp blown or loose in socket	Replace or tighten globe
Oven not hot enough	Heat escaping through incorrectly sealed door	Check shelves or dishes are not preventing door closing properly. Check that door is fitted properly after door removal for cleaning
	Door seal is worn or has moved	Replace seal or refit it
Unit smoking when first used	Protective oils being removed	This is normal
Odour on first use of oven		This is normal. Allow 2-4 hours for odour to dissipate (open all windows)
Oven shelf tight	Oven shelf not inserted correctly, may be upside down or back to front	Remove shelf and insert as per diagram

**Note: Do not attempt to repair this cooker yourself. Please call our Repairs Team on 01759 487835.**

# Product support

## Help and assistance

If you require any technical guidance or find that your cooker is not operating as intended, a simple solution can often be found in the **Troubleshooting** section of these instructions or online at [www.altimo.co.uk](http://www.altimo.co.uk).

If you still require further assistance, call one of our experts on **0330 041 7490**. To help us give you a fast and efficient service, please have the following information ready:

Model Ref.	<input type="text"/>	Model Ref. can be found on the ratings plate at rear of appliance and Serial number can be found on a sticker inside the door grill.
Serial number	<input type="text"/>	
Date of purchase	<input type="text"/>	This will be shown on your receipt.

Local call rates apply\*

Lines open 9.00am – 5.00pm Monday to Friday.

\*Calls to support enquiry lines may attract a charge and set up fee from residential lines depending on your call plan/tariff. Mobile and other providers costs may vary, see [www.bt.com/pricing](http://www.bt.com/pricing) for details.

For Security and training purposes, telephone calls to and from customer service centres may be recorded and monitored. Calls from Republic of Ireland will attract international call charges.

# Your Appliance Guarantee

## Guarantee Details (UK only)

Your appliance has the benefit of a comprehensive manufacturer's guarantee which covers the cost of repair due to mechanical or electrical breakdown.

Any claim during the period of the guarantee must be accompanied by proof of purchase.

The appliance must be correctly installed and operated in accordance with the manufacturer's instructions.

Your appliance is intended for normal domestic use and not for commercial operations.

This guarantee does not cover cosmetic issues with the appliance or failures caused by accidental damage, misuse or alterations which are likely to affect the appliance.

The guarantee is invalid if the product is tampered with or repaired by any unauthorised person.

What to do if you need to report a problem:

1. Please ensure you have ready:

- The product model and serial number
- Your full contact details

2. Call the specialist Service Line for your product: **01759 487835**

This guarantee in no way affects your statutory or legal rights.

Any information provided to us for the purposes of product support is subject to our privacy policy, which can be viewed online at [www.altimo.co.uk/privacy-policy](http://www.altimo.co.uk/privacy-policy)

## Declaration of conformance to product standards

This appliance conforms to all relevant standards applicable to domestic appliances sold in the UK

## Disposal



This appliance/fitting is marked according to the European directive 2012/19/EU on Waste Electrical and Electronic Equipment (WEEE).

By ensuring this product is disposed of correctly, you will help prevent potential negative consequences for the environment and human health, which could otherwise be caused by inappropriate waste handling of this product.

The symbol on the product, or on the documents accompanying the product, the **crossed-out wheellie bin** symbol, indicates that this appliance/fitting may not be treated as household waste. Instead it shall be handed over to the applicable collection point for the recycling of electrical and electronic equipment.

Disposal must be carried out in accordance with local environmental regulations for waste disposal.

For more detailed information about treatment, recovery and recycling of this product, please contact your local authority, your household waste disposal service or the retailer where you purchased the product.



[www.altimo.co.uk](http://www.altimo.co.uk)

For customer service call: 0330 041 7490