



# Instruction Manual



**Built-in Single Fan Oven**

**BISOF1SS / BISOF1B**

# Contents

## **1 Safety information**

Safety information 3

## **2 Getting to know your Built-in Oven**

Overview 5

Accessories 6

## **3 Installing your Built-in Oven**

Cabinet installation 7

Electrical connection 8

## **4 Using your Built-in Oven**

Oven functions 10

Using your three button programmer 11

General oven and cooking tips 14

## **5 Care and Maintenance**

Cleaning 16

Replacing the lamps 17

Technical specification 18

## **6 Product support**

Troubleshooting 19

Help and assistance 20

Your appliance guarantee 21

Declaration of conformance to product standards 22

Disposal 22



## Safety information

**Important** - Please read these instructions fully before installing or operating

### INSTALLATION WARNINGS

**IMPORTANT:** Prior to installation, ensure that the local supply conditions (electricity, voltage and frequency) are compatible with the requirements of your built-in oven.

**IMPORTANT:** Carefully unpack and examine the appliance for any damage. If you think there is a defect, do not use the appliance and contact Product Support on 0330 041 7490. Packaging materials should be collected together and disposed of immediately as they may be harmful to children.

**IMPORTANT:** Keep the electrical cable of your built-in oven away from the hot areas of your appliance, do not let the cable touch the appliance. Keep the cable away from sharp edges and heated surfaces.

**IMPORTANT:** Ensure that the electric supply cable is not trapped or damaged during installation.

**IMPORTANT:** In the event that the cable connecting your built-in oven becomes damaged, it must be replaced by a suitably qualified person. This cable must not be replaced by an unauthorised person.

**IMPORTANT:** Protect your built-in oven against atmospheric effects. Do not expose your oven to effects such as sun, rain, snow etc.

**IMPORTANT:** The materials surrounding the appliance (cabinets) must be able to withstand a minimum temperature of 100°C.

**IMPORTANT:** When using your oven for the first time, it may give off an unusual odour from the heating elements and insulation materials. This is normal for cooking appliances. To eliminate this odour run the oven at 250°C for 40-60 mins with the oven empty.

**WARNING:** Before obtaining access to terminals, all supply circuits must be disconnected.

### DURING USAGE

**IMPORTANT:** This appliance can be used by children aged from 8 years and above and persons with reduced physical, sensory or mental capabilities or lack of experience and knowledge if they have been given supervision or instruction concerning use of the appliance in a safe way and understand the hazards involved. Children should not play with the appliance. Cleaning and user maintenance should not be made by children without supervision.

**WARNING:** The appliance and its accessible parts become hot during use. Care should be taken to avoid touching heating elements. Children less than 8 years of age should be kept away unless continuously supervised.

**WARNING:** NEVER try to extinguish a cooking fire with water. Instead, switch off the appliance and cover the flame e.g. with a lid or a fire blanket.

**CAUTION:** Do not allow children in the kitchen when cooking or after, as the appliance may still be hot. Many parts of the oven become hot and present a considerable hazard to children.

**CAUTION:** When the oven is hot, never touch the oven glass by hand or with tools.

**CAUTION:** Before starting to use your appliance, ensure curtains, paper or flammable items are kept away from your appliance. Do not keep flammable materials inside of or around your oven.

**CAUTION:** Take care when closing the oven door that there is nothing obstructing it from closing as this may break the glass.

**IMPORTANT:** When using the grill, the oven door must be kept closed.



## Safety information

**Important** - Please read these instructions fully before installing or operating

**IMPORTANT:** Make sure the oven control knobs are all in the off position when not in use.

**IMPORTANT:** If you do not intend to use your built-in oven for a long period of time, turn off the electric supply to the oven.

### GENERAL SAFETY WARNINGS

**IMPORTANT:** This appliance has been designed for non-professional, domestic use only. Do not use this oven for commercial use or any other application e.g. room heating.

**WARNING:** Danger of fire: do not store flammable items on or near the cooking surfaces or inside the oven.

**IMPORTANT:** Do not try to lift or move this appliance by pulling on the door handle.

**WARNING:** Ensure that the appliance is switched off before replacing the lamp to avoid the possibility of electric shock.

**IMPORTANT:** Your appliance is produced in accordance with all applicable local and international standards and regulations.

**IMPORTANT:** Maintenance and repair work must only be performed by authorised service technicians. Installation and repair work that is carried out by unauthorised technicians is dangerous and could invalidate your guarantee.

**IMPORTANT:** When the door of the oven is open, do not hang or lean anything on it. You may unbalance your appliance or damage the door or door hinges.

**IMPORTANT:** Do not hang towels, dishcloths or clothes from the built-in oven or its handles.

### CLEANING AND MAINTENANCE

**IMPORTANT:** Always turn the appliance off before operations such as cleaning or maintenance. You can do this by switching the built-in oven off using the cooker isolation switch.

**IMPORTANT:** Do not remove the control knobs to clean the control panel.

**WARNING:** Do not use harsh abrasive cleaners or sharp metal scrapers to clean the oven door glass since they can scratch the surface, which may result in shattering the glass.

TO MAINTAIN THE EFFICIENCY AND SAFETY OF YOUR APPLIANCE, WE RECOMMEND YOU ALWAYS USE OUR AUTHORISED SERVICE AGENTS AND ORIGINAL SPARE PARTS.

**IF YOU REQUIRE ASSISTANCE WITH THE OPERATION OF YOUR APPLIANCE, PLEASE CALL OUR PRODUCT SUPPORT TEAM ON 0330 041 7490.**

**TROUBLESHOOTING ADVICE CAN BE FOUND ON PAGE 20. IF YOUR APPLIANCE IS FAULTY AND NEEDS A REPAIR, PLEASE CALL 0300 024 5648.**

# Getting to know your Freestanding Cooker

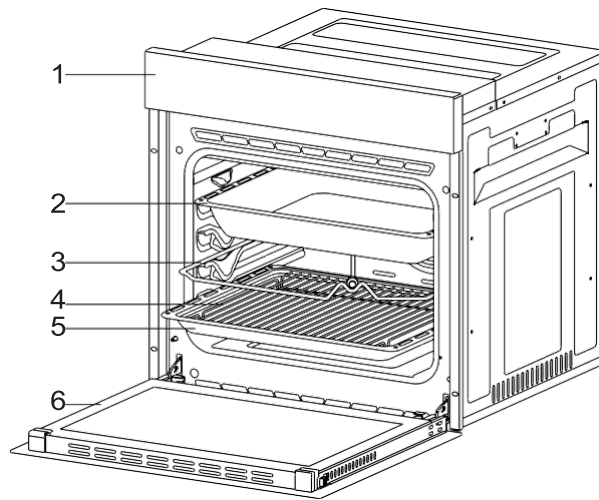

- |                          |                       |
|--------------------------|-----------------------|
| 1. Control pan           | 4. In tray wire grill |
| 2. Tray *                | 5. Standard tray      |
| 3. Roast chicken skewer* | 6. Oven door          |

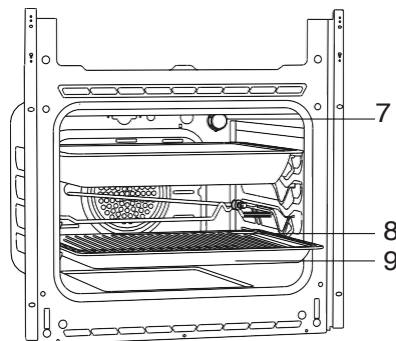

- |                       |
|-----------------------|
| 7. Lamp               |
| 8. In tray wire grill |
| 9. Standard tray      |

N.B. \* Not all shelves are included with this model

# Getting to know your Built-in Oven

## Built-in Oven Accessories

- 1 x Baking tray
- 1 x Grill insert
- 1 x Chrome shelf
- 1 x Fixing kit



### Baking Tray

Used for pastry (cookie, biscuit etc.), frozen foods.



### Grill Insert

Used for grilling by placing in baking tray or use with tray in oven shelf position for roasting



### Chrome Shelf

Used for roasting or placing foods to be baked, into desired rack.

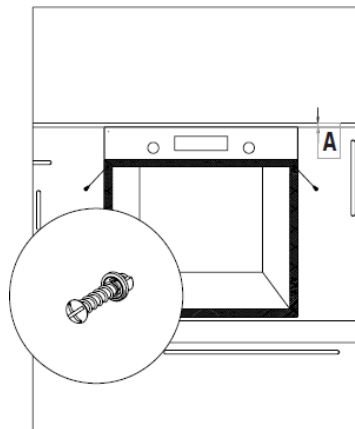

### Fixing Kit (screws)

Used to hold oven in cavity

## Tools needed for installation



Pencil

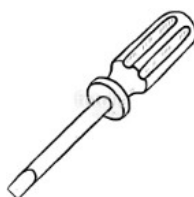

Cross head screwdriver



Electric drill

# Installing your Built-in Oven

Bringing it all together

## Installation

**This appliance should be installed by a competent person or qualified electrician in accordance with the regulations in force (All relevant British Standard/ Codes of Practice/relevant Building/IET regulations) and in a well-ventilated space. Please read all instructions before installing and using this appliance.**

Important: The power supply to the appliance must be cut off before any adjustments or maintenance work is carried out.

## Installation of Built-in Ovens

In order to ensure that the built-in appliance functions properly, the cabinet containing it must be appropriate. The figure below gives the dimensions of the cut-out for installation under the counter or in a wall cabinet unit.

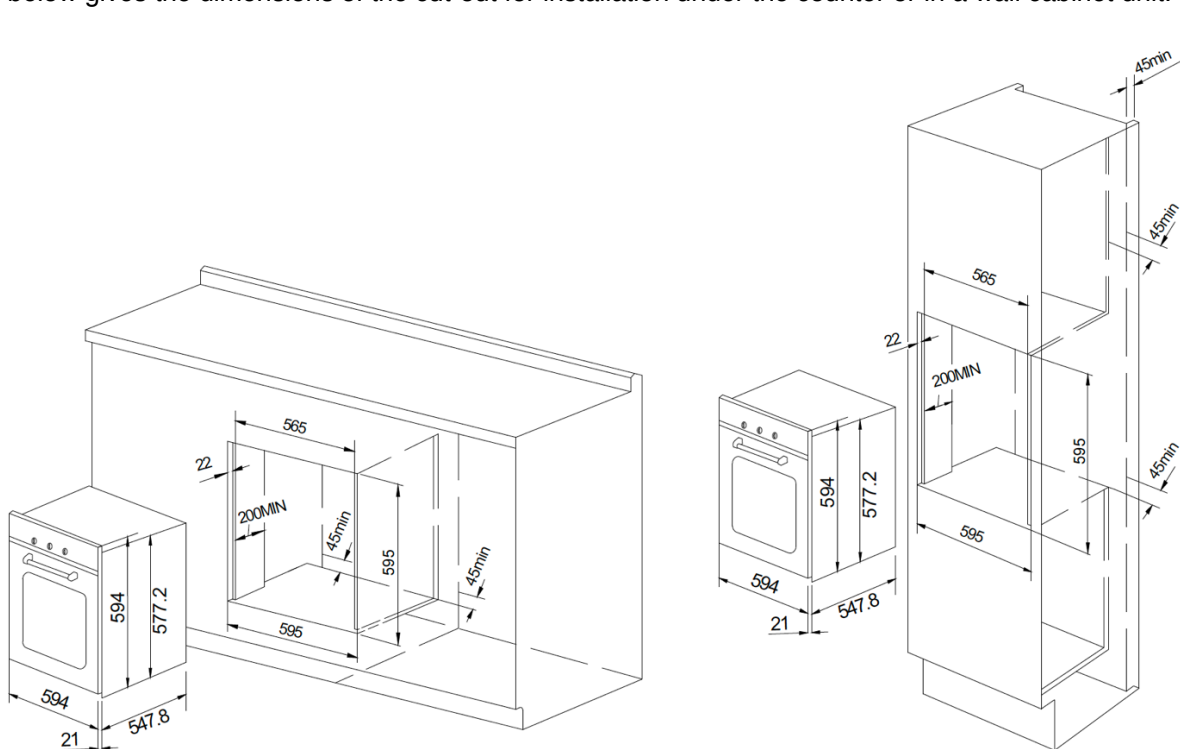

The worktop and any associated hob should be fitted **BEFORE** installing this oven.

It is recommended that if installing a built-in oven directly under the hob there should be a minimum air gap of 20mm between the oven and the bottom of the hob. Failure to maintain a suitable clearance may impair the performance of the hob.

Ensure that air can flow freely around the housing area. If the oven is being installed into a fully enclosed built-under oven housing unit, it may be necessary to cut a small slot in the top of the plinth fitted under the unit. Cut a section 400mm wide and a minimum of 15mm high to allow air to pass under the unit. Alternatively cut a section 400x450mm in the base of the carcass. Failure to allow adequate ventilation to the appliance may result in overheating or damage to adjacent units and could invalidate the guarantee.

Surfaces of furniture and walls adjacent to the appliance should be heat, splash and steam resistant. All cabinet doors must be at least 4mm from the oven at all points.

Certain types of vinyl or laminate kitchen furniture are particularly prone to heat damage and discolouration. We cannot accept responsibility for damage caused by normal use of the appliance to any material that de-laminates or discolours at temperatures less than 65°C above room temperature.

When placing the oven in the housing, do not use the oven door or handle as a lever for lifting the oven as damage may occur as a result.

If you lower the oven door, you will see 4 screw holes; 2 on each side of the oven. The oven should then be secured to the housing by fitting screws into these holes.

# Installing your Built-in Oven

Bringing it all together

## Provision for Ventilation

The appliance housing used must provide adequate ventilation.

For built-in installation, a minimum ventilation space of 40mm must exist between the rear of the appliance and the back of the housing or an adjacent wall.

If a tall housing is to be installed flush with the ceiling, a 20cm<sup>2</sup> ventilation cut-out must be provided at the top of the housing.

## Electrical Connection

Your new oven is provided from the Altimo factory with a UK standard plug, ready to fit straight into the nearby 13a cooker socket found in most modern homes.



For situations where a home does not have a standard 13a socket, the socket can be removed, and the cable fitted following the instructions on the next page.



# Installing your Built-in Oven

## Bringing it all together

This appliance must be installed by a qualified electrician to comply with the relevant Institution of Engineering and Technology (I.E.T.) regulations and also the local electricity supply company requirements.

### **WARNING: THIS APPLIANCE MUST BE EARTHED**

This appliance must be connected by a competent person, using fixed wiring via a double pole switched fused spur outlet, protected by a 13A fuse.

We recommend that the appliance is connected by a qualified electrician, who is a member of the N.I.C.E.I.C. and who will comply with the I.E.T. and local regulations. The wires in the mains lead are coloured in accordance with the following code:

This appliance must not be connected to an ordinary domestic power point. The mains terminal is situated on the back of the oven.

- **GREEN AND YELLOW = EARTH**
- **BLUE = NEUTRAL**
- **BROWN = LIVE.**

As the colours of the wires in the mains lead for the appliance may not correspond with the coloured markings identifying the terminals in your spur box, proceed as follows:

1. The wire which is coloured green and yellow must be connected to the terminal marked E (Earth) or coloured Green.
2. The wire which is coloured blue must be connected to the terminal marked N (Neutral) or coloured Black.
3. The wire which is coloured brown must be connected to the terminal marked L (Live) or coloured Red.

Connect the cable to the correct terminals. Check that the links are correctly fitted and that the terminal screws are tight. Secure the mains cable using the cable clamp. Ensure the cable route avoids the risk of trapping or touching hot surfaces.

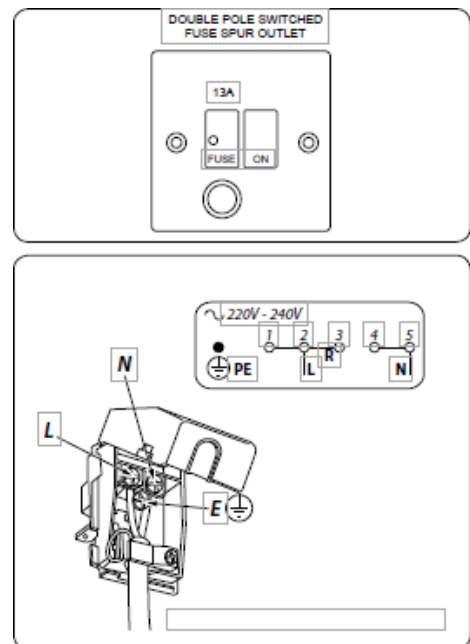

### **Current Operated Earth Leakage Breakers**

Where the installation is protected by a 30mA sensitivity residual current device (RCD), the combined use of your appliance and other domestic appliances may occasionally cause nuisance tripping. In these instances, the kitchen circuit may need to be reconfigured. This work should be carried out by a qualified electrician.

# Using your Built-in Oven

Getting the most from your appliance

## Oven functions



Grill



Fan grill



Fan oven



Defrost

**Oven light** - The oven light will operate on all oven functions.

**Grill** - The top central heating elements come on. The extremely high and direct temperature of the grill makes it possible to brown the surface of meats and roasts while locking the juices in to keep them tender. The grill is also highly recommended for dishes that require a high temperature on the surface: beef steaks, veal, rib steak, fillets, hamburgers etc.

**Fan grill** - The top central heating elements and the fan come on. This combination of features increases the effectiveness of the unidirectional thermal radiation of the heating elements through forced circulation of the air throughout the oven. This helps prevent food from burning on the surface, allowing the heat to penetrate right into the food. Excellent results are achieved with kebabs made with meats and vegetables, sausages, ribs lamb chops, chicken in a spicy sauce, quail, pork chops, etc.

**Fan oven** - When set to Fan oven mode, the fan element and the fan operate providing a delicate heat distributed uniformly throughout the oven. This mode is ideal for baking and cooking delicate foods on multiple shelves, especially cakes like Swiss rolls and small portions of vegetables, etc.

**Defrost** - When set to 'Defrost' mode, the fan located at the back of the oven circulates room temperature air around the food. This is recommended for the defrosting of all types of food, but in particular for delicate types of food which do not require heat, for example: ice cream cakes, cream or custard desserts, fruit cakes, etc. By using 'Defrost' mode, the defrosting time is approximately halved. In the case of meat, fish and bread, it is possible to accelerate the process by selecting 'Multi Cooking mode' and setting the temperature to 0°C (recircled air flow with no heat).

## Using your appliance for the first time

The first time you use your appliance, we recommend that you set the temperature setting to the highest mark. Set the cooking mode selection knob to a cooking mode and leave the oven on for about half an hour with nothing in it and the oven door shut. Then, open the oven door and allow the oven to cool. Any odour that may be detected during this initial use is due to the evaporation of substances used to protect the oven during storage.

# Using your Built-in Oven

Getting the most from your appliance

## Using your Three Button Timer

This model has an electronic timer with 24hr clock and three control buttons.

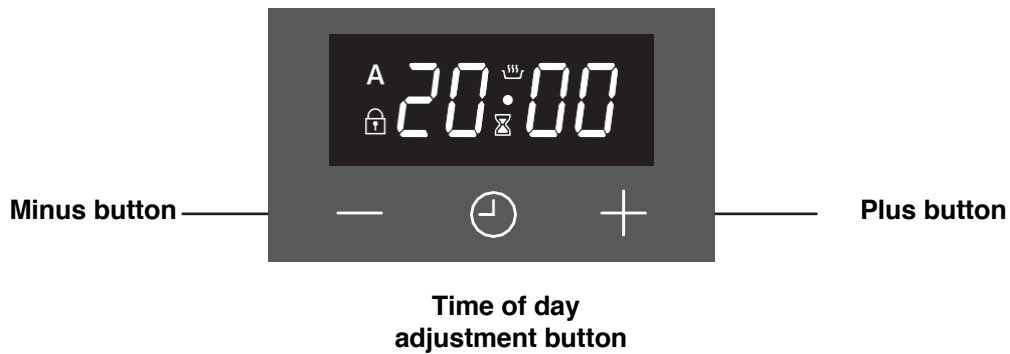

## Screen Symbols

	<b>Oven status indication</b> <ul style="list-style-type: none"><li>• <b>On:</b> Cooking or ready for cooking.</li><li>• <b>Off:</b> No cooking.</li></ul>
	<b>Minute minder status indication</b> <ul style="list-style-type: none"><li>• <b>On:</b> Minute minder alarm active.</li><li>• <b>Flashing:</b> Minute minder adjustment mode, adjustment possible by <b>+</b> or <b>-</b> buttons or current minute minder alarm completed.</li><li>• <b>Off:</b> Minute minder is not active.</li></ul>
	<b>Child lock indication</b> <ul style="list-style-type: none"><li>• <b>On:</b> Child Lock is active.</li><li>• <b>Off:</b> Child Lock is inactive.</li></ul>
	<b>Automatic cooking status indication</b> <ul style="list-style-type: none"><li>• <b>On:</b> Full or semi auto-cooking active.</li><li>• <b>Flashing:</b> Auto cooking completed or power on condition.</li><li>• <b>Off:</b> No auto cooking active.</li></ul>

# Using your Built-in Oven

## Getting the most from your appliance

The electronic timing module enables you to have your food cooked and ready at any time you like. The only thing you need to do is to programme the cooking time of the food and also the time when you would like your food to be ready. It is also possible to use a minute-programmed alarm clock independent from the oven. The oven time clock may be put back or forward according to mains frequency as it runs directly with mains voltage. This is not a malfunction.

### POWER ON

At power on, the oven is inactive, and time of day and **A** symbols are flashing. The indicated time of day is not correct and has to be adjusted. Press **⏻** to activate the oven and proceed adjusting the time of day as below.

### TIME OF DAY ADJUSTMENT

Time of Day adjustment is only possible when no cooking program is in progress. Press **+** and **-** simultaneously for 3 seconds to enter the adjustment mode, and then the dot symbol in between hours and minutes digits will start to flash. Using either **+** and **-** adjust the desired times. The maximum adjustable duration is 23h 59 minutes. Adjustment mode will be abandoned within 6 seconds after the last button press or can be terminated immediately by pressing the **⏻** button.

**Note:** Time of day adjustment is also activated in first 7 seconds after power on.

### SETTING THE MINUTE MINDER

Use this function to set a timer. After the adjusted time has been elapsed, an alarm will sound. Press the **⏻** button once to enter the minute minder adjustment mode, **⌚** symbol will start flashing on the screen. Using either **+** or **-**, adjust the desired duration. The maximum adjustable duration is 10 hours. Adjustment mode will be abandoned within 6 seconds after the last button press or can be terminated immediately by pressing the **⏻** button.

### CANCELLING THE ALARM BUZZER SOUND

Once the minute minder duration has elapsed, the buzzer alarm will start to sound, accompanied by the flashing **⌚** symbol on the screen. Any button press will stop the alarm sound and this indication. If no button is pressed, the alarm sound will end automatically after 5 minutes, but the flashing symbol will continue.

### SEMI-AUTOMATIC COOKING

This cooking program is intended to start cooking immediately for a specified duration after the oven is set to the desired function and temperature via the oven knobs:

1. Press the **⏻** button twice and the **A** symbol will flash on the screen. **dur** and the duration of cooking will show on the screen one after another.
2. Using the **+** or **-** buttons, adjust the desired cooking duration.
3. After 6 seconds of the last button press, or by pressing **⏻** twice, the adjustment is completed. **A** will be steady on the screen and the display shows the current time of day.

# Using your Built-in Oven

## Getting the most from your appliance

### FULLY AUTOMATIC COOKING

This cooking program is intended to perform a delayed cooking by programming the time of day, when the food should be ready. In other words, the oven will not start cooking immediately but will automatically calculate the time to start cooking.

1. Perform step 1 and 2 of the semi auto cooking as above **End** (cooking duration adjustment).
2. Press **⏸** button once again, **A** symbol will flash on the screen and duration of cooking will show on the screen one after another.
3. Using **−** or **+** buttons, adjust the desired end of cooking time. **🔔** symbol will disappear but **A** will be still flash on the screen. This indicates that an automatic cooking is programmed but cooking has not started.
4. After 6 seconds of the last button press, or by pressing **⏸**, the adjustment will be completed, the display shows the current time of day.

### END OF AUTO COOKING

When the cooking is finished automatically, the **A** icon starts to flash. The alarm may be turned off by pressing any key. To disable the key lock, press the **⏸** key for 2 seconds. The oven is taken to the manual mode by pressing the **⏸** key. Audible alarm shall sound for 7 minutes if you do not press any key.

### POWER INTERRUPTIONS

The cooker is not affected by short power failures (up to 50 seconds approximately), and the timer and the clock should resume working in this period. Your oven will be deactivated on longer power cuts due to safety reasons. This is indicated with the flashing of the clock and the **A** on the screen. The clock time will be displayed as **12:00** and it should be set again. (See POWER ON section)

**Note:** The flashing **A** symbol indicates that the oven is inactive, and you have to enter the manual mode.

### CHILD LOCK

This function is intended to prevent any unauthorized modification of the timer settings. This function will be active within 30 seconds after the last button press. **🔒** will appear. To de-active it, press the **⏸** button for 3 seconds. **🔒** will disappear.

### PROGRAMMABLE OPTIONS

#### Alarm tone:

Pressing and holding the **−** button for 3 seconds you will hear the current alarm tone. By pressing **+** and **−** buttons, you can scroll through 3 available buzzer tones. The last heard buzzer tone will be automatically recorded as the selected tone. After 6 seconds of the last button press or by pressing **⏸**, the adjustment is completed.

#### Brightness setting:

Pressing and holding the **+** button for 3 seconds will result in the current brightness setting being shown. By pressing **+** and **−** buttons, you can scroll through 8 available brightness settings. The last seen brightness setting will be automatically recorded as the selected setting. After 6 seconds of the last button press, or by pressing **⏸**, the adjustment is completed.

**Note:** Default settings are the highest options.

**Note:** Programmable options are non-volatile and will remain after any power failure.

# Using your Built-in Oven

## Getting the most from your appliance

### Practical Cooking Advice

The oven offers a wide range of alternatives that allow you to cook any type of food in the best possible way. With time you will learn to make the best use of this versatile cooking appliance and the following directions are only a guideline which may be varied according to your own personal experience.

#### Preheating

The oven must be preheated (this is generally the case when cooking leavened foods).

Once the food has been placed in the oven, the most appropriate cooking mode can then be selected.

#### Using the Grill

Use the "grill" mode , place the food under the centre of the grill (situated on the 3rd or 4th rack from the bottom) because only the central part of the top heating element is turned on.

Use the bottom rack (1st from the bottom), placing the dripping pan provided to collect any sauce and/or grease and prevent the same from dripping onto the oven bottom. When using this mode, we advise you to set the thermostat to 200°C, as it is the most efficient way to use the grill, which is based on the use of infrared rays. However, this does not mean you cannot use lower temperatures, simply by adjusting the thermostat knob to the desired temperature.

Therefore the best results when using the grill modes are obtained by placing the grid on the lower racks (see cooking table) then, to prevent fat and grease from dripping onto the bottom of the oven and smoke from forming, place a dripping-pan on the 1st oven rack from the bottom.

#### Baking Cakes

When baking cakes, always place them in a preheated oven. Make sure you wait until the oven has been preheated thoroughly (the pilot lamp will turn off). Do not open the oven door during baking to prevent the cake from dropping. In general:

##### **If cake / pastry is too dry**

Increase the temperature by 10°C and reduce the cooking time.

##### **If cake / pastry dropped**

Use less liquid or lower the temperature by 10°C.

##### **If cake / pastry is too dark on top**

Place it on a lower rack, lower the temperature, and increase the cooking time.

##### **If cake / pastry is cooked well on the inside but sticky on the outside**

Use less liquid, lower the temperature, and increase the cooking time.

##### **If cake / pastry sticks to the pan**

Grease the pan well and sprinkle it with a dusting of flour or use greaseproof paper.

##### **If you used more than one level and they are not all at the same cooking point**

Use a lower temperature setting. It is not necessary to remove the food from all of the racks at the same time.

#### Cooking Fish and Meat

When cooking white meat, fowl and fish, use a temperature setting from 180°C to 200°C.

For red meat that should be well done on the outside while tender and juicy in the inside, it is a good idea to start with a high temperature setting (200°C-220°C) for a short time, then turn the oven down afterwards.

In general, the larger the roast, the lower the temperature setting. Place the meat on the centre of the grid and place the dripping pan beneath it to catch the fat.

Make sure that the grid is inserted so that it is in the centre of the oven. If you would like to increase the amount of heat from below, use the low rack heights. For savoury roasts (especially duck and wild game), dress the meat with lard or bacon on the top.

# General oven and cooking tips

## General Oven Tips

The wire shelves should always be pushed firmly to the back of the oven.

Baking trays with food cooking on them should be placed level with the front edge of the oven's wire shelves. Other containers should be placed centrally. Keep all trays and containers away from the back of the oven, as over-browning of the food may occur.

For even browning, the maximum recommended size of a baking tray is 340 mm (13½") by 340 mm (13½").

When the oven is on, do not leave the door open for longer than necessary, otherwise the knobs may get very hot.

- Always leave a "finger's width" between dishes on the same shelf. This allows the heat to circulate freely around them.
- To reduce fat splashing when you add vegetables to hot fat around a roast, dry them thoroughly or brush lightly with cooking oil.
- Where dishes may boil and spill over during cooking, place them on a baking tray.

## Using the Grill

Use the 'Grill' mode with the oven door ajar, place the food on the centre of the grill pan, insert and fit the grill pan on either the 3rd or 4th shelf from the bottom. Note: only the central part of the top heating element operates for grilling.

When using 'Grill' mode, we recommend you set the thermostat to the highest setting. However, this does not mean you cannot use lower temperatures, simply adjust the thermostat knob to the desired temperature.

# Care and maintenance

## Looking after your appliance

### Cleaning

**WARNING!** Isolate the power supply to the appliance and make sure that the oven is cool.

**Before cleaning your oven or performing maintenance, make sure that the cooking mode selection knob and the cooking temperature selection knob are set to 'OFF'. To extend the life of your oven, it should be cleaned frequently.**

The inside of the oven should preferably be cleaned immediately after use, when it is still warm (but not hot), with warm water and soap. The soap should be rinsed away and the interior dried thoroughly. Avoid using abrasive detergents, scourers, acidic cleaners such as lime scale remover, etc, as these could damage the enamel, and can result in the development of rust and corrosion. If stains are particularly tough to remove, use cleaners specifically recommended to clean ovens and follow the instructions provided with the cleaner.

**Never use a steam cleaner for cleaning inside the oven.**

Do not clean using caustic creams, abrasive cleaning powders, thick wire wool or hard tools. Enamelled parts of the oven can be damaged if excess cleaning liquids are not immediately removed. After cleaning the interior parts of the oven with a soapy cloth, rinse it and then dry thoroughly with a soft cloth.

Clean the glass surfaces with special glass cleaning agents.

**Never** use flammable agents like acid, thinner or petrol when cleaning your oven.

**Do not** clean your oven with a steam cleaner.

**Do not** wash any part of your oven in a dishwasher.

#### **Enamelled Parts:**

In order to keep enamelled parts as new, it is necessary to clean them frequently with mild warm soapy water and then dry with a cloth. Do not wash them while hot and never use abrasive powders or abrasive cleaning materials. Do not leave anything spilled onto enamelled parts for long periods of time.

#### **Stainless Steel:**

Stainless steel parts must be cleaned frequently with mildly warm soapy water and a soft sponge and then dried with a soft cloth. Do not use abrasive powders or abrasive cleaning materials. Do not leave anything spilled onto stainless steel parts for long periods of time.



# Care and maintenance

## Replacing the oven lamps

**WARNING:** Ensure that the appliance is switched off before replacing the lamp to avoid the possibility of electric shock.

Remove the glass cover of the lamp-holder as shown below.

Remove the lamp and replace with a lamp resistant to high temperatures (300°C) with the following characteristics:

- Voltage: 220-240V
- Wattage: 25W
- Type: E14

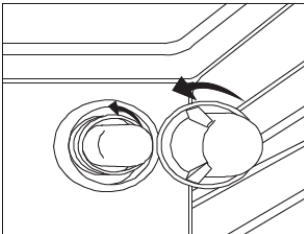

Replacement lamps are available from our Support Team. Replace the glass cover and reconnect the oven to the mains power supply.

**WARNING:** Please do not use screwdrivers or other utensils to remove the light cover. This could damage the enamel of the oven or the lamp holder.

**PLEASE NOTE:** The bulb replacement is not covered by your guarantee.

# Care and maintenance

## Technical specifications

<b>Model</b>	<b>BISOF1SS / BISOF1B</b>
<b>Voltage and frequency</b>	220-240V AC / 50Hz
<b>Grill Power</b>	2000W
<b>Oven Usable Capacity</b>	56L
<b>Total Power</b>	2055W
<b>Energy Rating</b>	A
<b>Recommended fuse size</b>	8.97

We apologise for any inconvenience caused by minor inconsistencies within these instructions that may occur due to product improvements and development. All images and drawings are for illustration purposes only.

# Product support

Help is always at hand

## Troubleshooting

**PLEASE DO NOT** attempt to repair this appliance yourself please contact the support contact centre on 0330 041 7490 or consult a qualified electrician

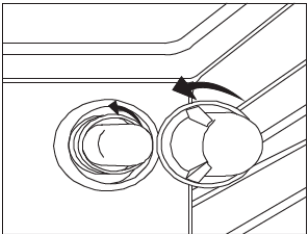
Problem	Possible Cause
<b>The oven does not heat up</b>	The oven may not be switched on. Switch oven on. A household fuse may have blown, or a circuit breaker may have tripped. Replace the fuses or reset the circuit. If this happens repeatedly, call an authorised electrician.
<b>A noise can be heard after a cooking programme</b>	The cooking fan remains switched on after the end of a cooking programme.
<b>The light/lamp is not working</b>	 <p>Disconnect the appliance from the electricity supply: Switch off and unplug at the socket, disconnect the fuse, or switch off at the isolator as appropriate.</p> <ul style="list-style-type: none"> <li>- Turn the lamp anti-clockwise to release it and then pull it downwards to take it out.</li> <li>- Replace it with a new halogen lamp.</li> <li>- Refit the lamp cover and turn it clockwise to secure it.</li> <li>- Reconnect the appliance to the main electricity supply.</li> </ul>
<b>Cakes and biscuits are browning unevenly</b>	There will always be a slight unevenness. If browning is very uneven check that the correct temperature was set and that the correct shelf level was used.
<b>Steam is coming from the oven</b>	When cooking foods with a high-water content (e.g. oven chips) there may be some steam visible at the top of the door, as there may be a momentary puff of steam when the door is opened. Stand back and allow any steam to disperse.
<b>The knobs get hot when I use the oven or the grill. Can I avoid this?</b>	Yes, this is caused by heat rising from the oven or the grill and heating them up. Do not leave the oven door open. Make sure that the grill pan is pushed right back to the 'back stop' when grilling. Always grill with the compartment door closed.
<b>Oven temperature getting hotter as the cooker gets older</b>	If turning the temperature down using the oven control knob has not worked, or has only worked for a short time, then you may need a new thermostat. This should be fitted by a service person.
<b>Grill not cooking properly</b>	Are you using the pan and trivet supplied with the cooker? Is the pan being used on the runners, not the floor of the compartment? Is the grill tray pushed fully back to stop?
<b>The oven is not cooking evenly</b>	If you are cooking a large item, be prepared to turn it round during cooking. Ensure the shelves are in the correct positions

# Product support

## Help and assistance

If you require any technical guidance or find that your oven is not operating as intended, a simple solution can often be found in the **Troubleshooting** section of these instructions or online at [www.altimo.co.uk](http://www.altimo.co.uk).

If you still require further assistance, call one of our experts on **0330 041 7490**. To help us give you a fast and efficient service, please have the following information ready:

Model Ref.

Serial number

Date of purchase

You can find these on the rating plate - a small information panel (usually a sticker or metal plate) on the rear of your appliance.

This will be shown on your receipt.

Local call rates apply\*

Lines open 9.00am – 5.00pm Monday to Friday.

\*Calls to support enquiry lines may attract a charge and set up fee from residential lines depending on your call plan/tariff. Mobile and other providers costs may vary, see [www.bt.com/pricing](http://www.bt.com/pricing) for details.

For Security and training purposes, telephone calls to and from customer service centres maybe recorded and monitored. Calls from Republic of Ireland will attract international call charges.

# Your Appliance Guarantee

## Guarantee Details (UK only)

Your appliance has the benefit of a comprehensive manufacturer's guarantee which covers the cost of repair due to mechanical or electrical breakdown.

Any claim during the period of the guarantee must be accompanied by proof of purchase.

The appliance must be correctly installed and operated in accordance with the manufacturer's instructions.

Your appliance is intended for normal domestic use and not for commercial operations.

This guarantee does not cover cosmetic issues with the appliance or failures caused by accidental damage, misuse or alterations which are likely to affect the appliance.

The guarantee is invalid if the product is tampered with or repaired by any unauthorised person.

What to do if you need to report a problem:

1. Please ensure you have ready:
  - The product model and serial number
  - Your full contact details
2. Call the specialist Service Line for your product: **0330 024 5648**

This guarantee in no way affects your statutory or legal rights.

Any information provided to us for the purposes of product support is subject to our privacy policy, which can be viewed online at [www.altimo.co.uk/privacy-policy](http://www.altimo.co.uk/privacy-policy)

## Declaration of conformance to product standards

This appliance conforms to all relevant standards applicable to domestic appliances sold in the UK.

## Disposal



This appliance/fitting is marked according to the European directive 2012/19/EU on Waste Electrical and Electronic Equipment (WEEE).

By ensuring this product is disposed of correctly, you will help prevent potential negative consequences for the environment and human health, which could otherwise be caused by inappropriate waste handling of this product.

The symbol on the product, or on the documents accompanying the product, the **crossed-out wheellie bin** symbol, indicates that this appliance/fitting may not be treated as household waste. Instead it shall be handed over to the applicable collection point for the recycling of electrical and electronic equipment.

Disposal must be carried out in accordance with local environmental regulations for waste disposal.

For more detailed information about treatment, recovery and recycling of this product, please contact your local authority, your household waste disposal service or the retailer where you purchased the product.



[www.altimo.co.uk](http://www.altimo.co.uk)

For customer service call: 0330 041 7490