



Instruction Manual



Solid Plate Hob

BEHS1SS

Contents

1 Safety information

Safety information 3

2 Getting to know your Hob

Overview 5

Accessories 6

3 Installing your Hob

Installation requirements 7

Installation guide 8

Electrical connections 10

4 Using your Hob

Operation 11

Advice 11

Utensils 12

5 Care and Maintenance

Cleaning 13

Technical specifications 14

6 Product support

Troubleshooting 15

Help and assistance 16

Your Appliance Guarantee 17

Declaration of conformance to
product standards 18

Disposal 18



Safety information

Important - Please read these instructions fully before installing or operating

INSTALLATION WARNINGS

IMPORTANT: Prior to Installation, ensure that the local supply conditions (electricity, voltage and frequency) are compatible with the requirements of your built-in hob.

IMPORTANT: Carefully unpack and examine the appliance for any damage. If you think there is a defect, do not use the appliance and contact Product Support on 0330 041 7490. Packaging materials should be collected together and disposed of immediately as they may be harmful to children.

IMPORTANT: Keep the electrical cable of your built-in hob away from the hot areas of your appliance. Do not let the cable touch the appliance. Keep the cable away from sharp edges and heated surfaces.

IMPORTANT: Ensure that the electric supply cable is not trapped or damaged during installation.

IMPORTANT: In the event that the cable connecting your built-in hob becomes damaged, it must be replaced by a suitably qualified person. This cable must not be replaced by an unauthorised person.

IMPORTANT: Protect your built-in hob against atmospheric effects. Do not expose your hob to effects such as sun, rain, snow etc.

IMPORTANT: The materials surrounding the appliance (cabinets) must be able to withstand a minimum temperature of 100°C.

IMPORTANT: When using your appliance for the first time your built-in hob may give off an unusual odour from the heating elements. This is normal for cooking appliances.

WARNING: Before obtaining access to terminals, all supply circuits must be disconnected.

DURING USAGE

IMPORTANT: This appliance can be used by children aged from 8 years and above and persons with reduced physical, sensory or mental capabilities or lack of experience and knowledge if they have been given supervision or instruction concerning use of the appliance in a safe way and understand the hazards involved. Children should not play with the appliance. Cleaning and user maintenance should not be carried out by children without supervision.

WARNING: The appliance and its accessible parts become hot during use. Care should be taken to avoid touching heating elements. Children less than 8 years of age shall be kept away unless continuously supervised.

WARNING: NEVER try to extinguish a cooking fire with water. Instead switch off the appliance and cover flame e.g. with a lid or a fire blanket.

CAUTION: Do not allow children in the kitchen when cooking or after, as the parts may still be hot. Many parts of the hob will become hot and present a considerable hazard to children.

CAUTION: When the hob is hot, never touch the ceramic plates by hand or with tools.

CAUTION: Before starting to use your appliance, ensure curtains, paper or flammable items are kept away from your appliance. Do not keep flammable materials on or around your built-in hob.



Safety information

Important - Please read these instructions fully before installing or operating

IMPORTANT: Make sure the built-in hob control knobs are all in the off position when not in use.

IMPORTANT: If you do not intend to use your hob for a long period of time, turn off the electric supply to the hob.

GENERAL SAFETY WARNINGS

IMPORTANT: This appliance has been designed for non-professional, domestic use only. Do not use this hob for commercial use or any other application e.g. room heating.

WARNING: Danger of fire - do not store flammable items on or near the cooking surfaces of the appliance.

IMPORTANT: Do not try to lift or move this appliance by pulling on the control knobs.

IMPORTANT: Your appliance is produced in accordance with all applicable local and international standards and regulations.

IMPORTANT: Maintenance and repair work must only be performed by authorised service technicians.

Installation and repair work that is carried out by unauthorised technicians is dangerous and could invalidate your guarantee.

IMPORTANT: Do not leave towels, dishcloths or clothes on the built-in hob or its control knobs.

CLEANING AND MAINTENANCE

IMPORTANT: Always turn the appliance off before operations such as cleaning or maintenance. You can do this by switching the built-in hob off using the hob isolation switch.

IMPORTANT: Do not remove the control knobs to clean the control panel.

WARNING: Do not use harsh abrasive cleaners or sharp metal scrapers to clean the hob top since they can scratch the surface.

TO MAINTAIN THE EFFICIENCY AND SAFETY OF YOUR APPLIANCE, WE RECOMMEND YOU ALWAYS USE OUR AUTHORISED SERVICE AGENTS AND ORIGINAL SPARE PARTS.

IF YOU REQUIRE ASSISTANCE WITH THE OPERATION OF YOUR APPLIANCE, PLEASE CALL OUR PRODUCT SUPPORT TEAM ON 0330 041 7490.

TROUBLESHOOTING ADVICE CAN BE FOUND ON PAGE 15. IF YOUR APPLIANCE IS FAULTY AND NEEDS A REPAIR, PLEASE CALL 0330 041 7490.

Getting to know your Built-in Hob

You'll be up and running in no time

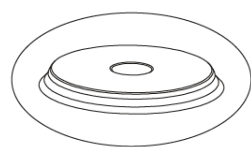
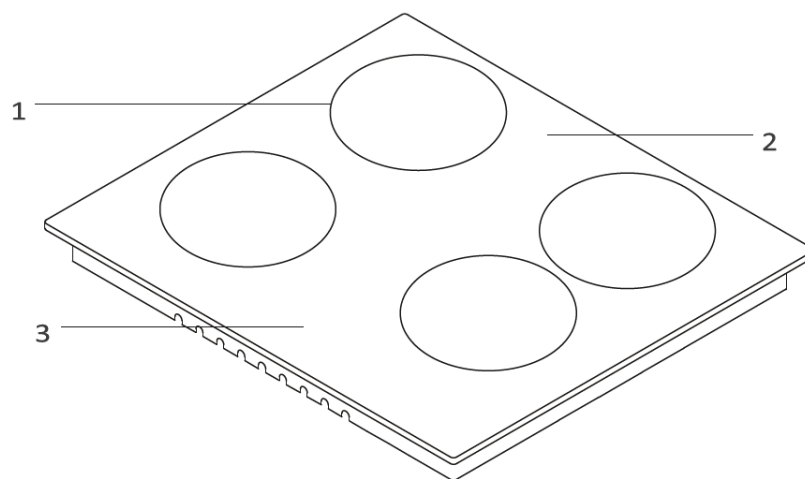
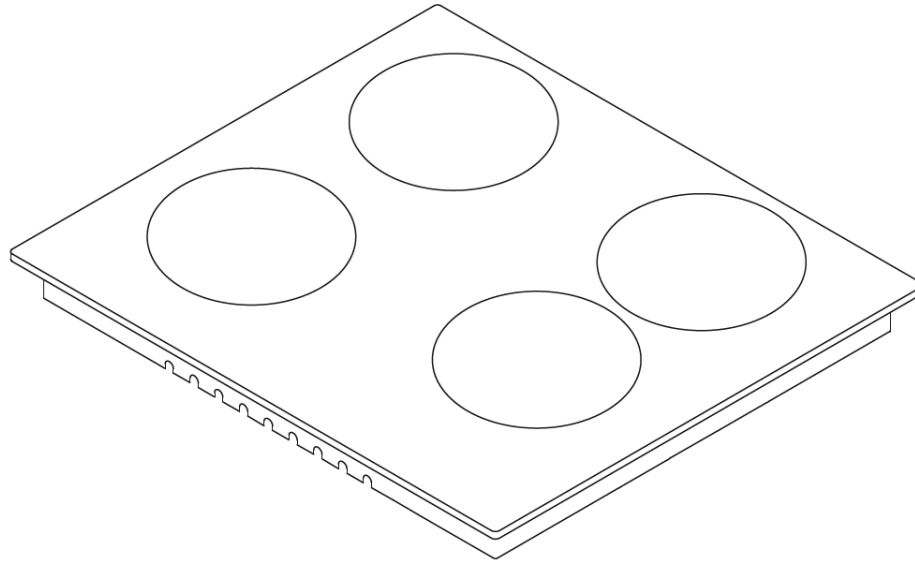

4

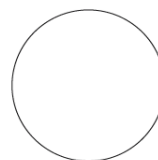

5

1. Heater positions
2. Glass or metal surface
3. Control switches
4. Hotplate (145 mm or 180 mm) *
5. Ceramic heater (180 mm or 140 mm) *

Getting to know your Built-in Hob

You'll be up and running in no time

Accessories

1



2



3



1. Bracket*4
2. Screw*4
3. Seal*1

Installing your Built-in Hob

Bringing it all together

WARNING: This appliance must be installed by an authorised service person or qualified technician, according to the instructions in this guide and in compliance with the current local regulations.

- Incorrect installation may cause harm and damage, for which the manufacturer accepts no responsibility and the warranty will not be valid.
- Prior to installation, ensure that the local distribution conditions (electricity voltage and frequency and/or nature of the gas and gas pressure) and the adjustments of the appliance are compatible. The adjustment conditions for this appliance are stated on the label.

The laws, ordinances, directives and standards in force in the country of use are to be followed (safety regulations, proper recycling in accordance with the regulations, etc.).

Instructions for the installer

General instructions

- After removing the packaging material from the appliance and its accessories, ensure that the appliance is not damaged. If you suspect any damage, do not use it and contact an authorised service person or qualified technician immediately.
- Make sure that there are no flammable or combustible materials in the close vicinity, such as curtains, oil, cloth etc. which may catch fire.
- The worktop and furniture surrounding the appliance must be made of materials resistant to temperatures above 100°C.
- If a cooker hood or cupboard is to be installed above the appliance, the safety distance between the cooktop and any cupboard/cooker hood should be as shown below.

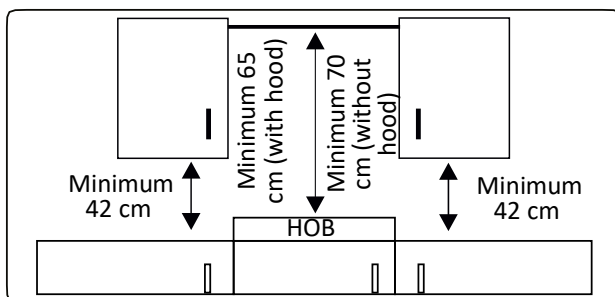

- The appliance should not be installed directly above a dishwasher, fridge, freezer, washing machine or clothes dryer.
- If the base of the appliance is accessible by hand, a barrier made from a suitable material must be fitted below the base of the appliance, ensuring that there is no access to the base of the appliance.
- If the hob is installed above an oven, the oven should have a cooling fan.

- The cut aperture dimensions are indicated below.

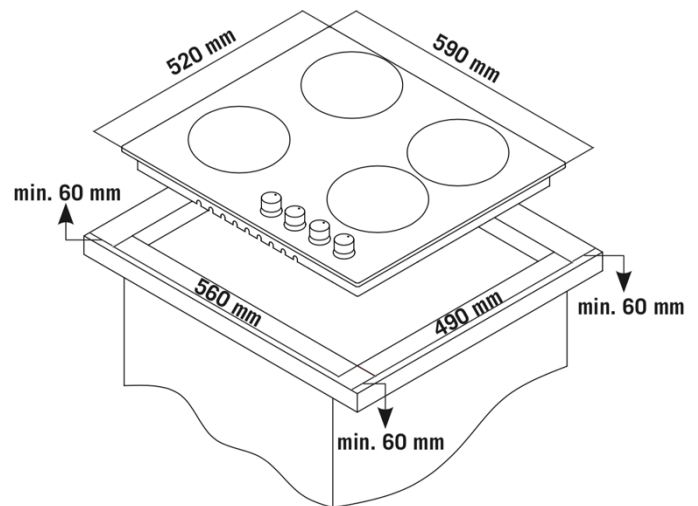

Installing your Built-in Hob

Bringing it all together

Fixing the seal to the back of the Hob

The hob must be sealed to the work surface to prevent liquid from entering into the cabinet. A tape seal is supplied with the hob. Refer to Fig. 1

1. Turn the hob over and place on a secure, level surface.
2. Spread the seal around the left, front, right and rear outer edges of the cooktop. Take special care in the corners making sure there are no gaps. The ends of the strips must fit together without overlapping.
3. If the surface that the hob is to be fitted to is tiled or is not reasonably smooth, additional sealing with a waterproof silicone sealant may be required.
4. Turn the hob back the right way up and position it in the worktop cut-out.

Fastening the Installation Brackets

Each cooktop is provided with an installation kit including brackets and screws for fastening the top to fixture panels from 20 to 40 mm thick. Refer to Fig. 2

1. Turn the cooktop upside down and fasten the brackets "F" and "R" to the appropriate socket holes, without tightening the screws for the moment.
2. NOTE: Dependent on the thickness of the worktop (as shown in Fig. 2), slide the optional sleeve onto the bracket if fitting to thin work surfaces.
3. Make sure that the brackets are fastened as shown in Fig. 2

Installing the Hob

1. Turn the hob back the right way up and position it in the worktop cut-out.
2. Insert the cooktop into the hole and position it correctly.
3. Adjust the position of the brackets "F" and "R" and tighten "Rear Screw" and "Front Screw" to lock the cooktop firmly in position (Fig. 2).
4. With a sharp cutter or trimmer knife trim the excess sealing material around the edge of the cooktop. Take care not to damage the workbench.

If the surface that the hob is to be fitted to is tiled or is not reasonably smooth, additional sealing with a waterproof silicone sealant may be required.

Installing your Built-in Hob

Bringing it all together

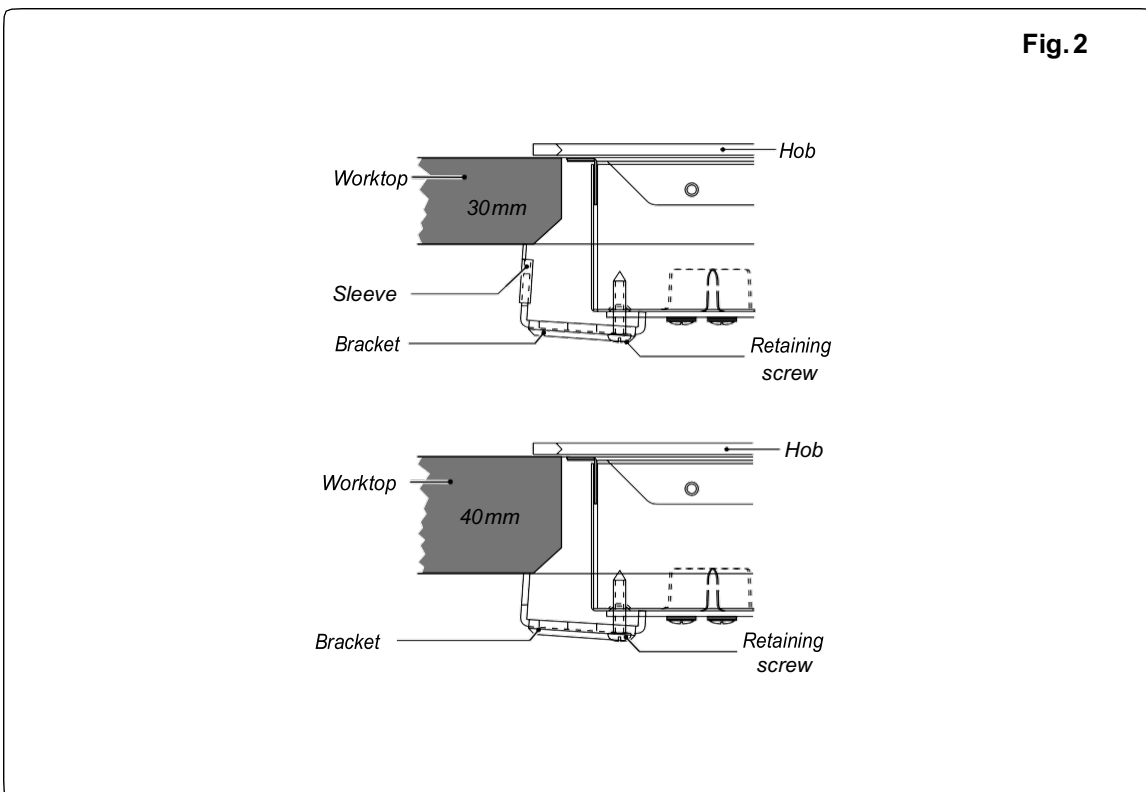
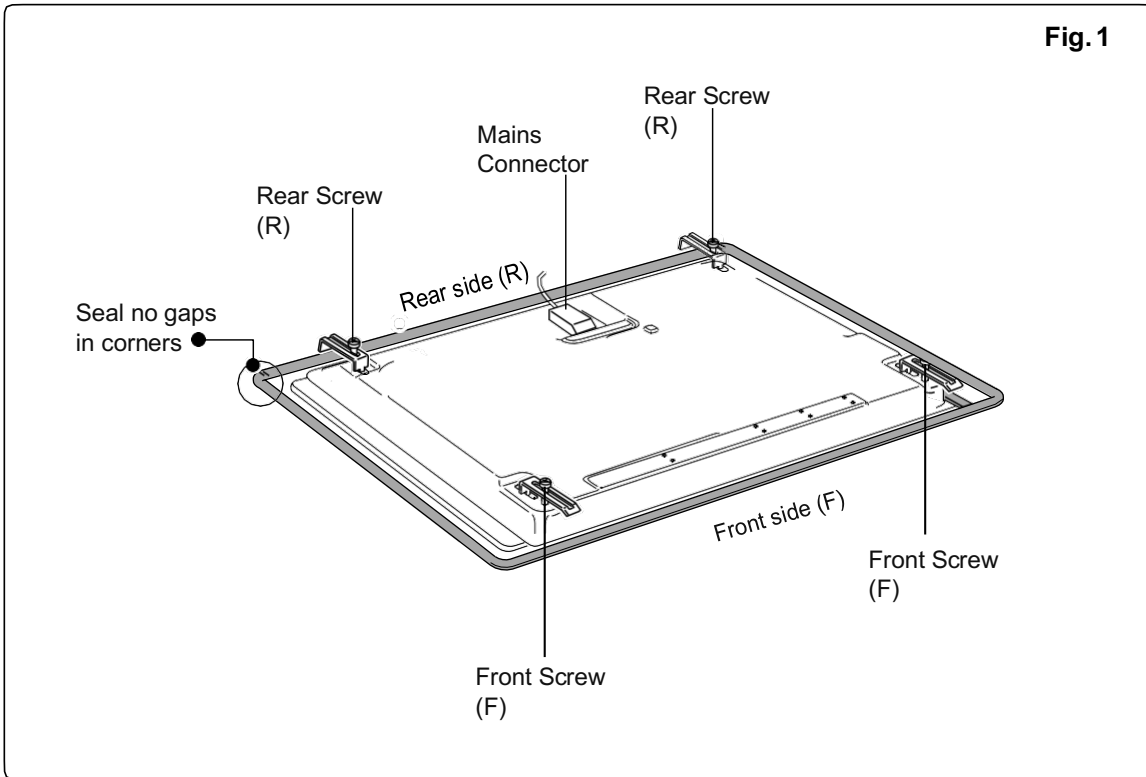

Figures for reference only

Installing your Built-in Hob

Bringing it all together

Electrical connection

Appliances with a three-pole cable are set up for operation with alternating current at the voltage and frequency indicated on the rating plate. The earth conductor is yellow/green. The connection to the electricity supply must be made by a qualified person and following the regulations in force.

When the appliance is to be installed above a built-in oven, the two appliances must be connected separately, to make it easier to take the appliances out and for electrical safety.

The supply cable must be positioned so that no point can reach a temperature 50°C higher than the ambient temperature.

Also check that the supply system has an effective earth connection and corresponds to the standards in force, and that the isolation switch can be reached easily when the appliance is installed.

IMPORTANT: The wires in the mains lead are coloured in accordance with the following code:

Green and yellow: Earth

Blue: Neutral

Brown: Live

Earth

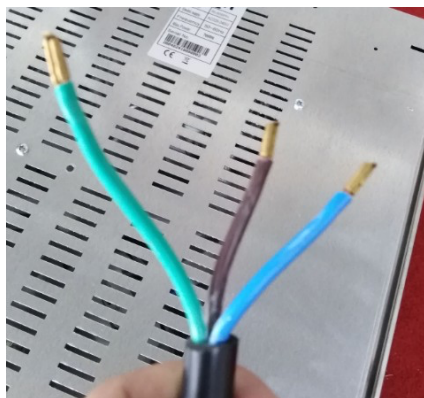

Live

Neutral

Using your Built-in Hob

Getting the most from your appliance

Operation of the top with the electric plates

The electric tops can either be of the standard type, or of the rapid type. The latter feature a red mark at their centre. According to your needs, the tops can be adjusted by turning the knobs either clockwise or anti-clockwise on 6 positions besides the 0 position (off).

The positions marked by the higher numerical index match the maximum output of heat (see table). When using rapid tops, a thermostat automatically reduces the power when the selected temperature is reached, and the top operates intermittently to reach a constant cooking temperature.

The pilot light set in the control area signals that the electric plates are switched on.

	Reheating		Cooking		Roasting-frying	
Normal and fast electric hot plates	1	2	3	4	5	6
Pyroceram tops Grill	1		2		3	

Advice on the use of cooking tops

To save energy and to have a longer product life, we advise using pans with a flat bottom and a diameter not lesser than the diameter of the hob tops. Care must be taken that fluids do not spill on the electric plates.

Never leave the plates on without pans on them or with empty pans, and never use the tops to heat the room. Always switch on the plates after the pans are in position. **Once switched off, the plates remain warm for a while.**

Switch off the heating element before removing the pans.

Using your Built-in Hob

Getting the most from your appliance

Utensils

- Use pans with flat bottoms. Uneven or thin bottoms will waste energy and are slow to cook
- Use pans slightly larger than the hotplates. Smaller pans will waste energy.
- Do not use oversized pans. More than 50mm overhang can overheat the hob components and can cause fine cracks in the enamel hob which will trap dirt.
- Use only dry utensils. Do not place wet or steamy parts (e.g. lids) on the hotplates.
- Do not use pots and pans that are unsteady and likely to rock or overbalance.
- Do not operate the hob for an extended time without a saucepan or pot on the hotplate.

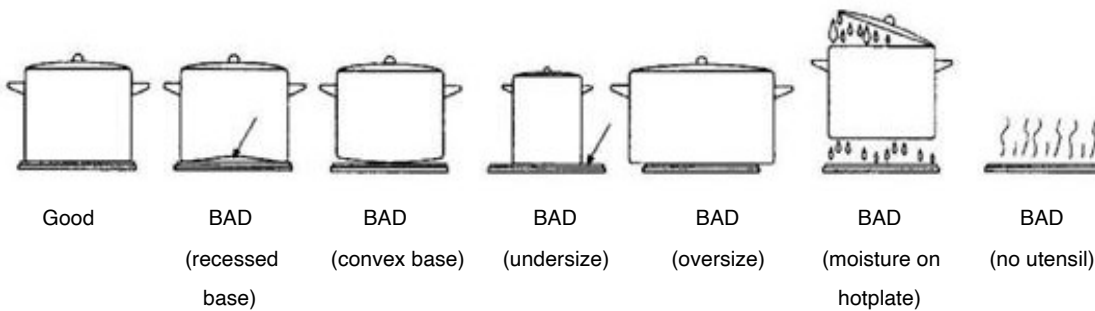

Care and maintenance

Looking after your appliance

Cleaning

WARNING! Isolate the power supply to the built-in hob and make sure that the built-in hob is cool.

Before cleaning your hob or performing maintenance, make sure that the cooking zone control knobs are set to 'OFF'. To extend the life of your hob, it must be cleaned frequently.

The built-in hob should preferably be cleaned immediately after use, when it is still warm (but not hot), with warm water and soap. The soap should be rinsed away and dried thoroughly. Avoid using abrasive detergents, scourers, acidic cleaners such as lime scale remover, etc, as these could damage the surface, and can result in the development of rust and corrosion. If stains are particularly tough to remove, use cleaners specifically recommended to clean stainless steel and follow the instructions provided with the cleaner. **Never use a steam cleaner for cleaning the appliance.**

Do not clean using caustic creams, abrasive cleaning powders, thick wire wool or hard tools.

Never use flammable agents like acid, thinner or petrol when cleaning your hob.

Do not wash any part of your hob in a dishwasher.

Stainless Steel:

Stainless steel parts must be cleaned frequently with mildly warm soapy water and a soft sponge and then dried with a soft cloth. Do not use abrasive powders or abrasive cleaning materials. Do not leave anything spilled onto stainless steel parts for long periods of time.

Care and maintenance

Looking after your appliance

Technical specification

Model	BEHS1SS
Voltage and frequency	220-240V AC / 50Hz
Power consumption for large hot plates	1500W (x2)
Power consumption for small hot plates	1000W (x2)
Total Power	5000W
Recommended fuse size	21.73

Product support

Help is always at hand

Troubleshooting

1. If no electrical functions appear to work, check the isolation switch has not been turned off, also check the fuse in the switch and your circuit breaker.
2. After replacing the fuse or resetting the circuit breaker, turn on individual parts of your hob one at a time to check function.
3. **DO NOT ATTEMPT TO REPAIR THIS APPLIANCE YOURSELF. CALL OUR PRODUCT SUPPORT TEAM ON 0330 041 7490 OR CONSULT A QUALIFIED ELECTRICIAN.**

Product support

Help and assistance

If you require any technical guidance or find that your hob is not operating as intended, a simple solution can often be found in the **Troubleshooting** section of these instructions or online at **www.altimo.co.uk**

If you still require further assistance, call one of our experts on **0330 041 7490**. To help us give you a fast and efficient service please have the following information ready:

Model Ref.	<input type="text"/>	You can find these on the rating plate - a small information panel (usually a sticker or metal plate) on the rear of your appliance.
Serial number	<input type="text"/>	
Date of purchase	<input type="text"/>	This will be shown on your receipt.

Local call rates apply*

Lines open 9.00am – 5.00pm Monday to Friday.

*Calls to support enquiry lines may attract a charge and set up fee from residential lines depending on your call plan/tariff. Mobile and other providers costs may vary, see www.bt.com/pricing for details.

For Security and training purposes, telephone calls to and from customer service centres may be recorded and monitored. Calls from Republic of Ireland will attract international call charges.

Your Appliance Guarantee

Guarantee Details (UK only)

Your appliance has the benefit of a comprehensive manufacturer's guarantee which covers the cost of repair due to mechanical or electrical breakdown.

Any claim during the period of the guarantee must be accompanied by proof of purchase.

The appliance must be correctly installed and operated in accordance with the manufacturer's instructions.

Your appliance is intended for normal domestic use and not for commercial operations.

This guarantee does not cover cosmetic issues with the appliance or failures caused by accidental damage, misuse or alterations which are likely to affect the appliance.

The guarantee is invalid if the product is tampered with or repaired by any unauthorised person.

What to do if you need to report a problem:

1. Please ensure you have ready:
 - The product model and serial number
 - Your full contact details
2. Call the specialist Service Line for your product: **0330 024 5648**

This guarantee in no way affects your statutory or legal rights.

Any information provided to us for the purposes of product support is subject to our privacy policy, which can be viewed online at www.altimo.co.uk/privacy-policy

Declaration of conformance to product standards

This appliance conforms to all relevant standards applicable to domestic appliances sold in the UK.

Disposal



This appliance/fitting is marked according to the European directive 2012/19/EU on Waste Electrical and Electronic Equipment (WEEE).

By ensuring this product is disposed of correctly, you will help prevent potential negative consequences for the environment and human health, which could otherwise be caused by inappropriate waste handling of this product.

The symbol on the product, or on the documents accompanying the product, the **crossed-out wheellie bin** symbol, indicates that this appliance/fitting may not be treated as household waste. Instead it shall be handed over to the applicable collection point for the recycling of electrical and electronic equipment.

Disposal must be carried out in accordance with local environmental regulations for waste disposal.

For more detailed information about treatment, recovery and recycling of this product, please contact your local authority, your household waste disposal service or the retailer where you purchased the product.



www.altimo.co.uk

For customer service call: 0330 041 7490